



## VALVOLE A SFERA

Ball valves  
Kugelventile  
Vannes à boule  
Valvulas de bola

# K

## VALVOLE A SFERA TIPO K

La Veneta Acciai ha progettato e realizzato le valvole tipo "K" con l'obiettivo di ottenere un prodotto altamente qualificato per il settore alimentare dove l'elevata igienicità, la flessibilità di impiego, la facile manutenzione e pulizia sono caratteristiche fondamentali. La massima attenzione è stata posta nel trovare le soluzioni più pratiche per la standardizzazione e la intercambiabilità, in modo da ottenere la massima praticità nei diversi impieghi. Fra le soluzioni tecniche adottate, va messa in particolare evidenza quella della sfera a movimento compensato che, tramite l'inserimento di O-Ring sotto i seggi di tenuta, permette di ottenere un movimento regolare e un minor irrigidimento della sfera in fase di impiego. Inoltre l'uso di viti passanti rende agevole e veloce lo smontaggio.

**Tutti i materiali usati sono compatibili per il contatto con alimenti in accordo al Regolamento Europeo CE 1935/2004 - FDA.**

## K TYPE BALL VALVES

Veneta Acciai has been carefully working during its planning and making process, in order to get a highly qualified product for the alimentary field, where high hygiene, flexibility and easy keeping are striking characteristics. Greatest care has been used to find useful and convenient solutions to get standard and interchangeable parts. A very special technical device is the ball counterbalanced movement, which is made through inserted O-rings under the ball keeping seals. This peculiar mechanism allows the "k type" valve to get a regular movement and a lower stiffening while using. Running through screws have been used for a quick and easy disassembly.

**All materials used are suitable for food contact according to the European Regulation (EC) No 1935/2004 - FDA.**

## KUGELVENTILE TYP K

Die Firma Veneta Acciai hat gerade in der Phase der Planung und der Herstellung von den Ventilen Typ "K" gearbeitet, um ein äußerst fortgeschrittenes Produkt zu erzielen, das in solchen Bereich der Nahrungsmittelindustrie eingeführt werden konnte wo ein hoher Grad der Hygiene gefragt wird und wo die Anpassungsfähigkeit, sowie die einfache Wartung und das Reinigen zu Grundeigenschaften gehören. Die größte Aufmerksamkeit wurde dem Erfinden der praktischen Lösungen für die Standardisierung und die Austauschbarkeit gewidmet, um die größte Zweckmäßigkeit in den verschiedenen Lösungen zu erzielen. Unten den angewendeten technischen Lösungen von besonderer Bedeutung ist die Kugel mit Sperrbewegung zu nennen. Durch das Einstecken von O-Ring unter den Dichtsitz auf der Weise, um eine regelmäßige Bewegung und eine kleinere Versteifung der Kugel in der Einsatzphase erzielen zu können, sowie die Einführung von durchgehenden Schrauben für eine leichte und schnelle Zerlegung. **Alle verwendeten Materialien sind mit Kontakt mit Lebensmitteln vereinbar, in Übereinstimmung mit der europäischen Verordnung (EG) Nr 1935/2004 - FDA.**

### CARATTERISTICHE TECNICHE

- Costruita da pezzi forgiati AISI 304L/316L - EC 1935/2004
- Facilmente smontabile per la pulizia e sostituzione delle guarnizioni
- Estremamente ridotta nell'ingombro
- Organo di comando a leva ad apertura a 180° o servocomandata elettricamente e ad aria
- Viti passanti per maggiore sicurezza
- Passaggio totale
- Connessioni standard DIN/Clamp/ SMS/GAS Eno/Macon e a richiesta
- Intercambiabilità delle calotte
- Fluidi di gruppo 2
- Finitura standard Ra 1,2 a richiesta Ra 0,6
- Produzione standard da DN 25 a DN 100
- Pressione di esercizio da DN 25/50, PN 16 da DN 60/100 PN 10
- Temperatura da 0° +120°C
- \* Per temperatura minore a 0°C utilizzare sistema KTP pag.115
- **Collaudo al 100%**

● Sfera a 3° foro + scarico di drenaggio sul MOD. KTP (vedi disegno)

### TECHNICAL DATA

- Built by forged pieces AISI 304L/316L - EC 1935/2004
- Easily detachable for the cleaning and substitution of the gaskets
- Extremely redoubt in the encumbrance
- Opening by 180° lever or by electrical and pneumatic actuators
- Running through screws for greater safety
- Total passage
- Standard connections DIN/Clamp / SMS/GAS Eno/Macon and on request
- Interchangeability of the caps
- Fluid of group 2
- Standard finish Ra 1,2 to in demand Ra 0,6
- Standard production from DN 25 to DN 100
- Pressure of working from DN 25/50 PN 16 from DN 60/100 PN 10
- Temperature from 0° +120°C
- \* For lower temperature use KTP system page 115
- **100% tested**

● Ball with 3° holes fitted + drain screw on KTP type (see the next drawing)

Veneta Acciai Srl dichiara che i propri prodotti e i materiali sono idonei e adatti al luogo e al tipo di installazione inoltre sono testati con attrezzature speciali.

In accordo con la vigente Direttiva 2014/68/CE (PED) si riportano di seguito le condizioni di utilizzo in funzione alle dimensioni nominali (DN) delle valvole:

Veneta Acciai Srl declares that own products are perfectly made using proper material suitable for place and type of installation and tested with special equipments.

In accordance with the current Directive 2014/68/CE (PED) terms of use are reported below on the nominal dimensions (DN) of valves:

### CLASSIFICAZIONE / CLASSIFICATION ( Allegato II / Annex II - 2014/68/CE )

Tipo valvola Valve type	DN (mm)	PN (bar)	Temperatura Temperature (°C)	Gruppo fluido Fluid group	Categoria di rischio Risk category	Marchio CE CE mark
VALVOLE A SFERA Ball valves	25 ÷ 50	16	-15 ÷ 120	2	Art. 4.3	NO
	60 ÷ 100	10	-15 ÷ 120	2	Art. 4.3	NO
	125	6	-15 ÷ 120	2	Art. 4.3	NO

Le informazioni contenute in questo documento sono puramente indicative e non impegnative, l'azienda si riserva il diritto di modificarle senza obbligo di preavviso.  
The informations provided in this document are intended for informational purposes only and are subject to change without notice.

## VALVOLA A SFERA "SEMPREPIENA"

"ALWAYS FULL" BALL VALVE

"IMMER VOLL" KUGELVENTIL

VANNE À BOULE "TOUJOURS PLEINE"

VALVULA DE BOLA "SEMPRE LLENA"

**brevetto**

patent

brevet

patente

n°.1141885



# mod. KTP

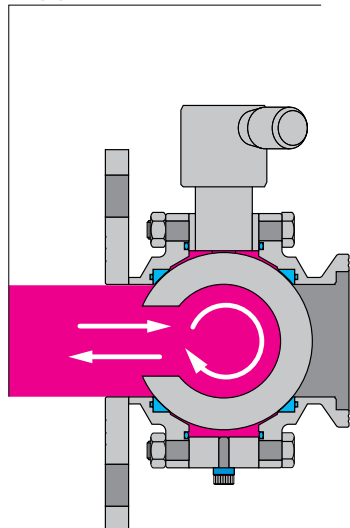

### 1 CHIUSA CLOSED

Sezione della valvola "SEMPREPIENA" in posizione chiusa; al suo interno, grazie a terzo foro, circola il prodotto contenuto nel serbatoio.

*Cross section of the "ALWAYS FULL" valve when closed. The wine in the tank circulates within the valve thanks to a third hole.*

*Querschnitt des „IMMER VOLL“ Ventils (Tank stets voll) in geschlossener Position. Durch die dritte Öffnung im Inneren strömt der im Tank enthaltene Wein.*

*Section de la vanne "TOUJOURS PLEINE" en position fermée ; grâce au troisième trou, le vin contenu dans le réservoir circule à l'intérieur.*

*Sección de la válvula "SIEMPRE LLENA" en posición cerrada; en su interior, gracias al tercer agujero, circula el vino contenido en el depósito.*

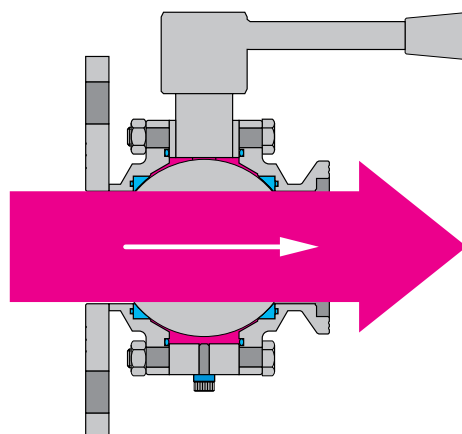

### 2 APERTA OPENED 90°

Sezione della valvola "SEMPREPIENA" in posizione aperta; con prodotto in uscita dal serbatoio.

*Cross section of the "ALWAYS FULL" valve when open. The wine is outlet from the tank*

*Querschnitt des Ventils „IMMER VOLL“ (Tank stets voll) in geöffneter Position. Der Wein läuft aus dem Tank heraus.*

*Section de la vanne "TOUJOURS PLEINE" en position ouverte; avec le vin en sortie du réservoir.*

*Sección de la válvula "SIEMPRE LLENA" en posición abierta; con vino a la salida del depósito.*

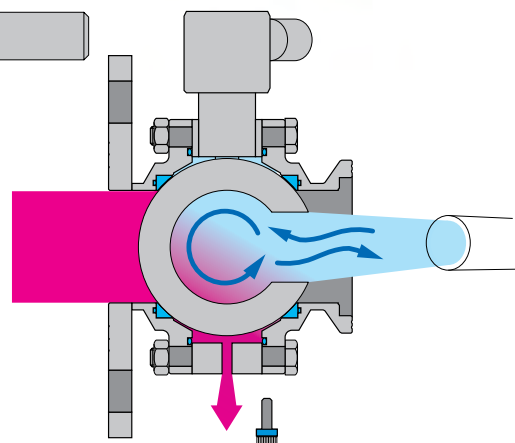

### 3 CHIUSA CLOSED 180°

Sezione della valvola "SEMPREPIENA" in posizione chiusa e maniglia ruotata di 180°, con serbatoio pieno e terzo foro in direzione di uscita per permettere le operazioni di lavaggio della valvola. Lo svitamento della vite inferiore consente lo scarico del contenuto.

*Cross section of the "ALWAYS FULL" valve when closed and handled turned 180°, with tank full and third hole facing outlet so that the valve can be washed. Unscrew the bottom screw to drain the contents.*

*Querschnitt des Ventils „IMMER VOLL“ (Tank stets voll) in geschlossener Position und Hebelgriff auf 180°. Tank voll und dritte Öffnung in Richtung Ventilausgang, um den Reinigungsvorgang des Ventils zu ermöglichen. Die untere Schraube dient zum Ablassen des Inhalts.*

*Section de la vanne "TOUJOURS PLEINE" en position fermée et poignée tournée à 180°, avec le réservoir plein et le troisième trou dirigé vers la sortie pour permettre les opérations de lavage de la vanne. Le dévissage de la vis inférieure permet la vidange du contenu.*

*Sección de la válvula "SIEMPRE LLENA" en posición cerrada y manilla girada 180°C, con depósito lleno y tercer agujero en dirección de la salida para permitir las operaciones de lavado de la válvula. El desenroscado del tornillo inferior permite descargar el contenido.*

**VALVOLE A SFERA**  
 Ball valves  
 Kugelventile  
 Vannes à boule  
 Vallvulas de bola

# K

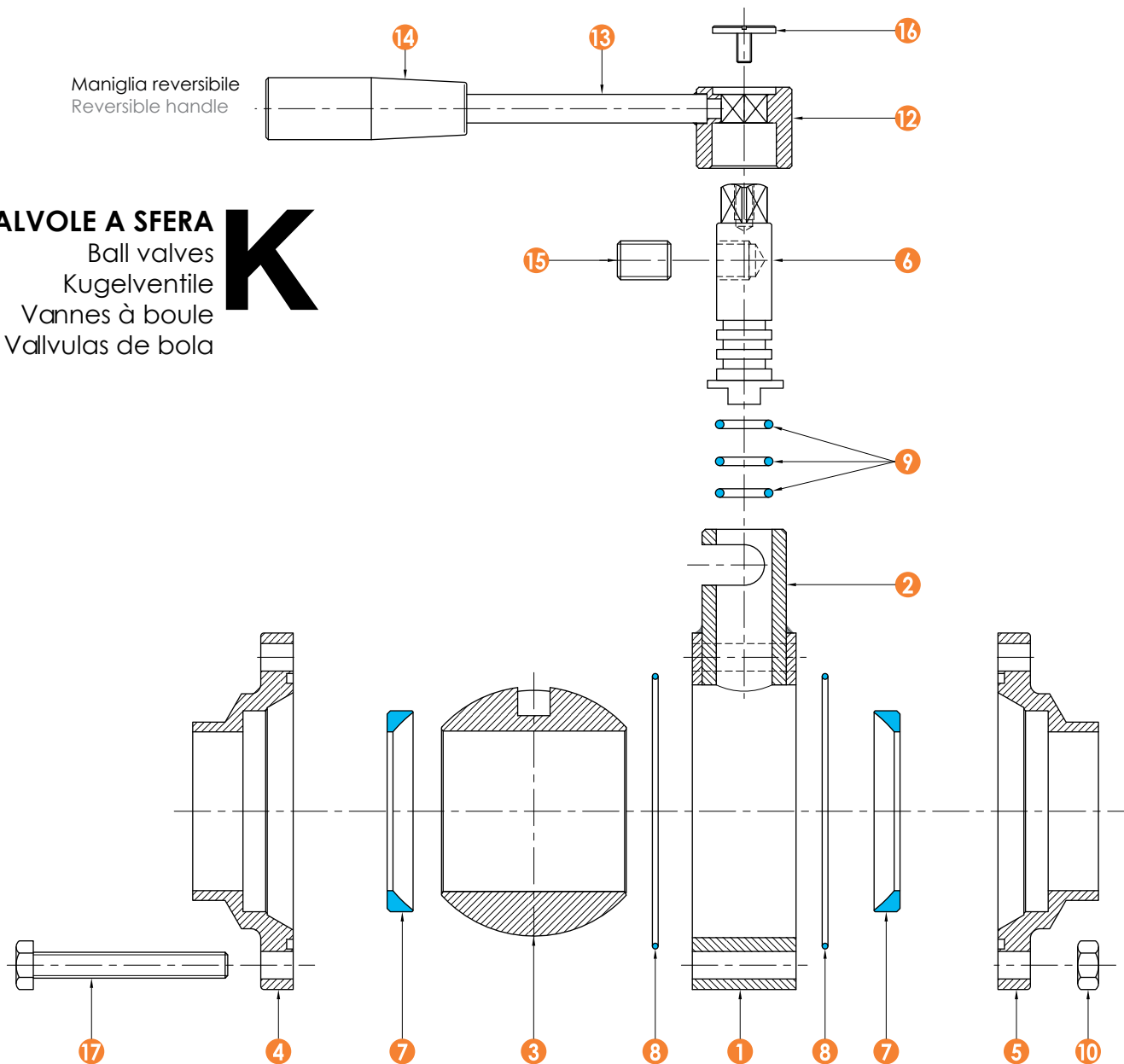

POS.	DENOMINAZIONE	PART NAME	MAT.
1	CORPO VALVOLA	BODY VALVE	AISI 304/316
2	BOCCOLA CORPO	BODY BUSH	AISI 304/316
3	SFERA	BALL	AISI 304/316
4	CUFFIA	CAP	AISI 304/316
5	CUFFIA	CAP	AISI 304/316
6	PERNO	PIN	AISI 304/316
7	SEDE SFERA	BALL SEAT	P.T.F.E
8	OR CUFFIA	CAP OR	NBR
9	OR PERNO	PIN OR	NBR
10	DADO ESAGONALE	EX. NUT	AISI 304
12	BOCCOLA MANIGLIA	HANDLE BUSH	AISI 304
13	ASTA MANIGLIA	HANDLE SHAFT	AISI 304
14	MANIGLIA	HANDLE	AISI 304
15	GRANO	SCREW	AISI 304
16	VITE	SCREW	AISI 304
17	VITE T.E.	SCREW	AISI 304

## Schema di montaggio valvole K con attuatore

Mounting drawing with K Valve Actuator

Montage-Zeichnung mit K Ventiltrieb

Schéma de montage vanne a boule K avec verin pneumatique

Esquema de montaje válvula de bola K con neumático

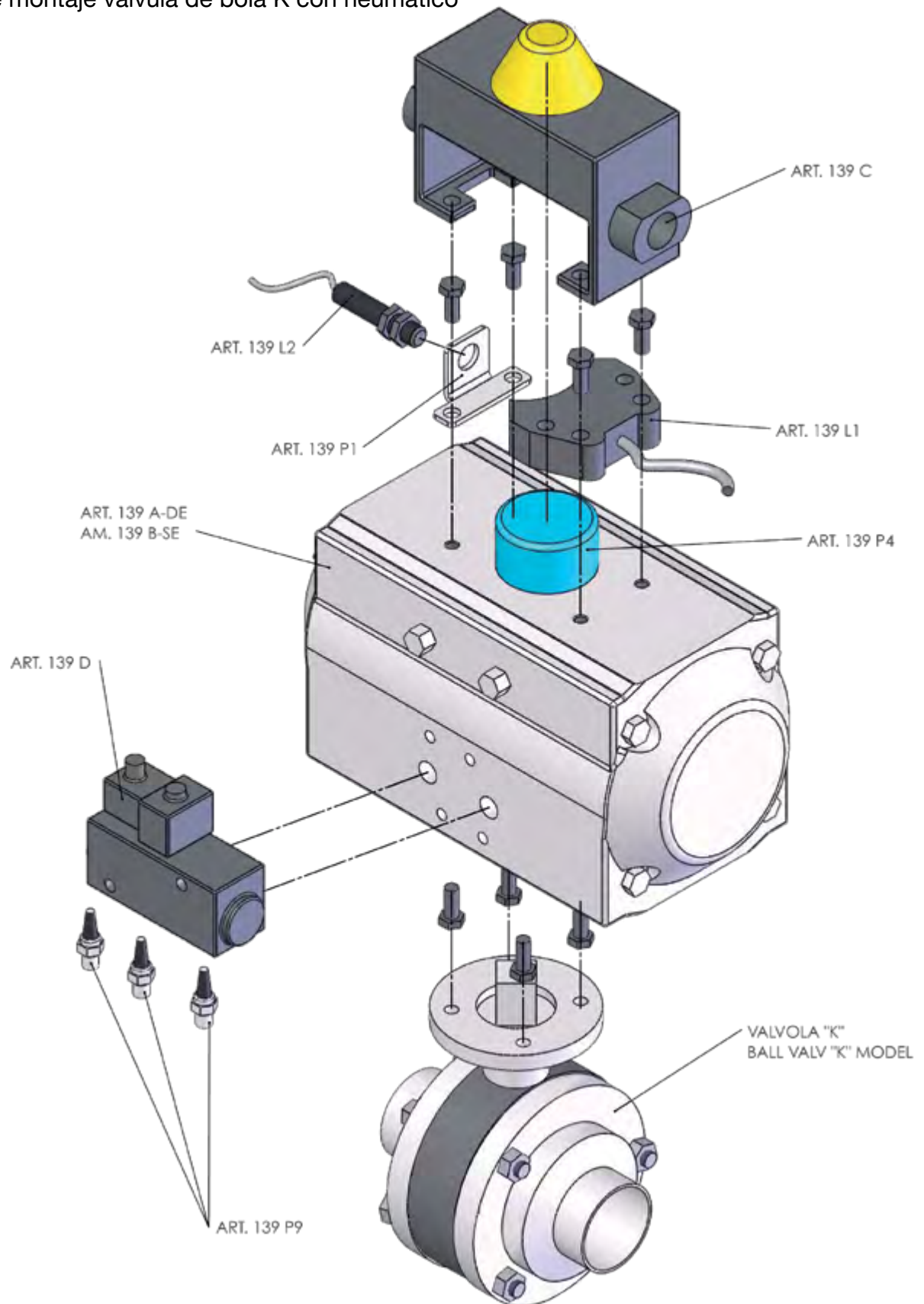

## Valvola a sfera K attacchi filettati SMS

K ball valve SMS male ends

K Kugelventil SMS G/G

Vanne à boule K bouts filetés SMS

Válvula de bola K macho - macho SMS

AISI 304 - 316

 art. **47**

DN	A	B	C	D	E	F
<b>25</b>	88	40x1/6"	24	73.5	122	
<b>38</b>	102	60x1/6"	35	95	180	
<b>51</b>	102	70x1/6"	49.5	100.5	180	
<b>63</b>	114	85x1/6"	57.5	125.5	266	
<b>76</b>	114	98x1/6"	69	136.5	266	
<b>100R</b>	206	125x1/6"	89	144.5	266	

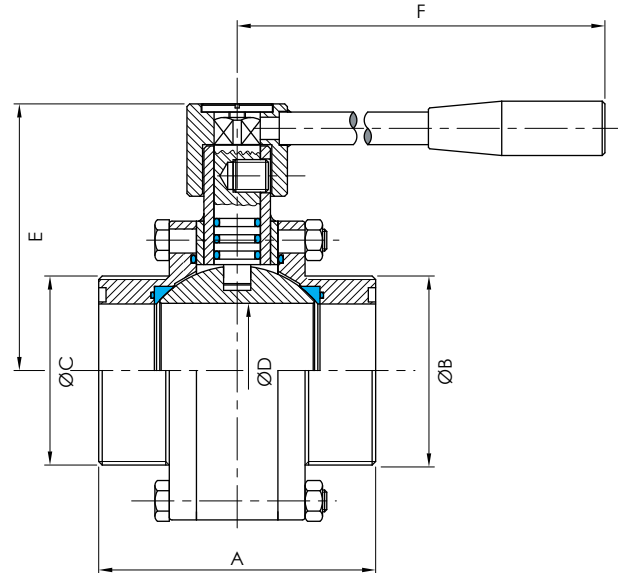

Ver. 04.18

## Valvola a sfera K maschio girella SMS - filetto SMS

K ball valve SMS nut and liner - male end

K Kugelventil SMS KM/G

Vanne à boule K mâle - femelle SMS

Válvula de bola K tuerca - macho SMS

AISI 304 - 316

 art. **48**

DN	A	B	C	D	E	F
<b>25</b>	88	40x1/6"	24	73.5	122	
<b>38</b>	102	60x1/6"	35	95	180	
<b>51</b>	102	70x1/6"	49.5	100.5	180	
<b>63</b>	114	85x1/6"	57.5	125.5	266	
<b>76</b>	114	98x1/6"	69	136.5	266	
<b>100R</b>	206	125x1/6"	89	144.5	266	

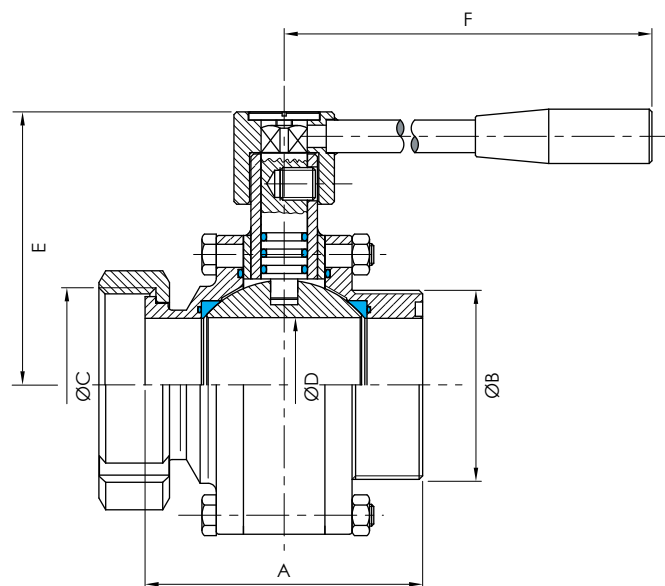

**Valvola a sfera K attacco flangia - uscita filetto SMS**

art. 49

K ball valve flange - SMS male end

K Kugelventil Flansch - SMS G

Vanne à boule K bride - bout fileté SMS

Válvula de bola K brida - macho SMS

AISI 304 - 316

DN	A	B	C	D	E	F	G	H	L
25	96	40x1/6"	85	24	73.5	14	115	4	122
38	110	60x1/6"	110	35	95	18	150	4	180
51	110	70x1/6"	125	49.5	100.5	18	165	4	180
63	124	85x1/6"	145	57.5	125.5	18	185	4	266
76	124	98x1/6"	160	69	136.5	18	185	4	266
100R	216	125x1/6"	180	89	144.5	18	200	8	266

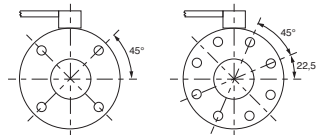

Posizione dei fori flangia rispetto alla valvola  
Position of the flange holes welded to the valve

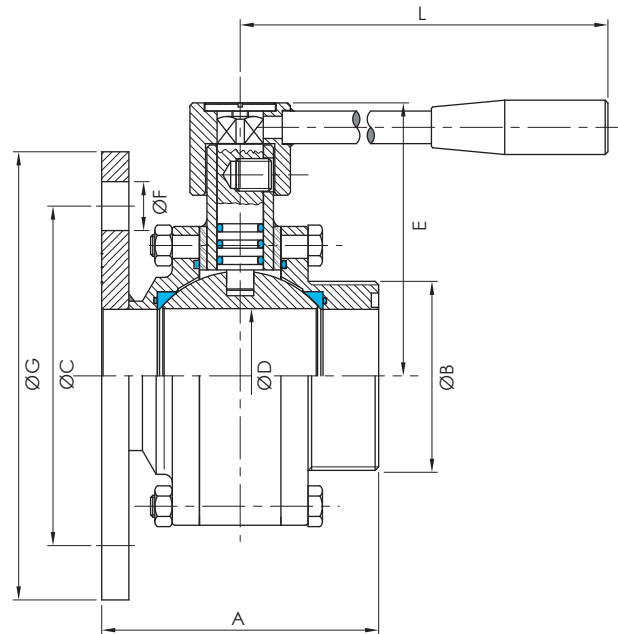

Ver. 04.18

**Valvola a sfera K a saldare SMS**

art. 50

K ball valve welding ends

K Kugelventil SMS S/S

Vanne à boule K bouts lisses SMS

Válvula de bola K soldar SMS

AISI 304 - 316

DN	A	B	C	D	E	F
25	88	28	28	24	73.5	122
38	102	38	38	35	95	180
51	102	51	51	49.5	100.5	180
63	114	64	64	57.5	125.5	266
76	114	76.5	76.5	69	136.5	266
100R	206	101	101	89	144.5	266

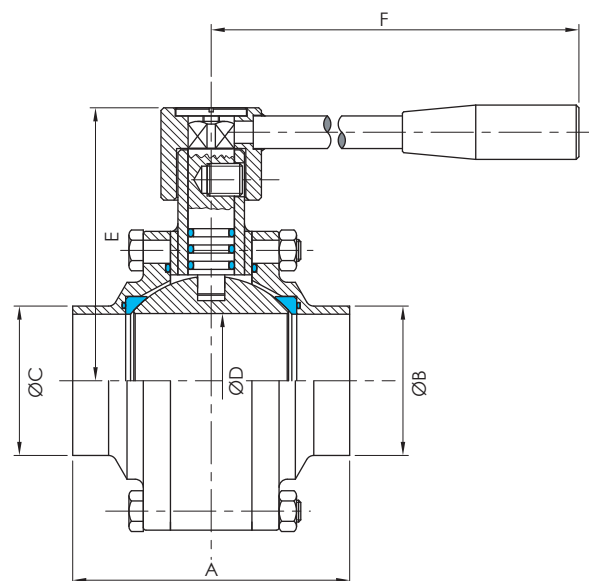

## Valvola a sfera K con attacchi filettati DIN

K ball valve DIN male ends

K Kugelventil DIN G/G

Vanne à boule K bouts filetés DIN

Válvula de bola K macho - macho DIN

 art. **52**

AISI 304 - 316

DN	A	B	C	D	E	F
25	88	52x1/6"		24	73.5	122
32	88	58x1/6"		33	79	122
40	102	65x1/6"		40	95	180
50	102	78x1/6"		49.5	100.5	180
60	114	84.5x1/6"		57.5	107.25	205
65	124	95x1/6"		65.5	125.5	266
80	152	110x1/4"		79	136.5	266
100R	154	130x1/4"		89	144.5	266

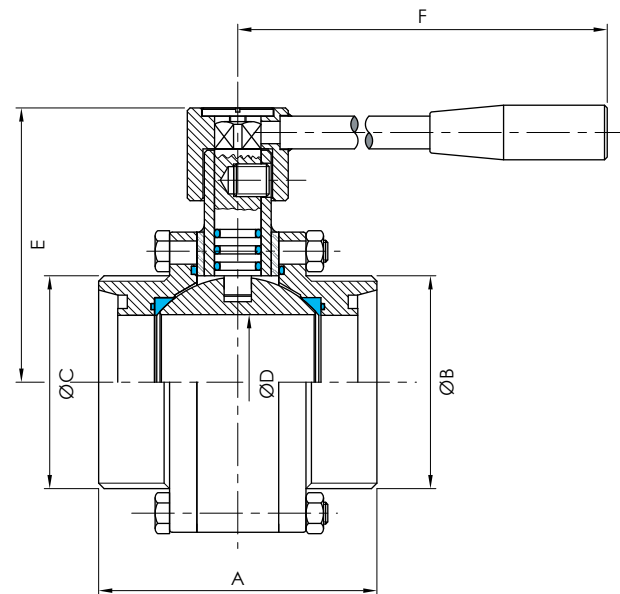

## Valvola a sfera K maschio girella - filetto DIN

K ball valve DIN nut and liner - male end

K Kugelventil DIN KM/G

Vanne à boule K mâle - femelle DIN

Válvula de bola K tuerca - macho DIN

 art. **53**

AISI 304 - 316

DN	A	B	C	D	E	F
25	88	52x1/6"		24	73.5	122
32	88	58x1/6"		33	79	122
40	102	65x1/6"		40	95	180
50	102	78x1/6"		49.5	100.5	180
60	114	84.5x1/6"		57.5	107.25	205
65	124	95x1/6"		65.5	125.5	266
80	152	110x1/4"		79	136.5	266
100R	154	130x1/4"		89	144.5	266

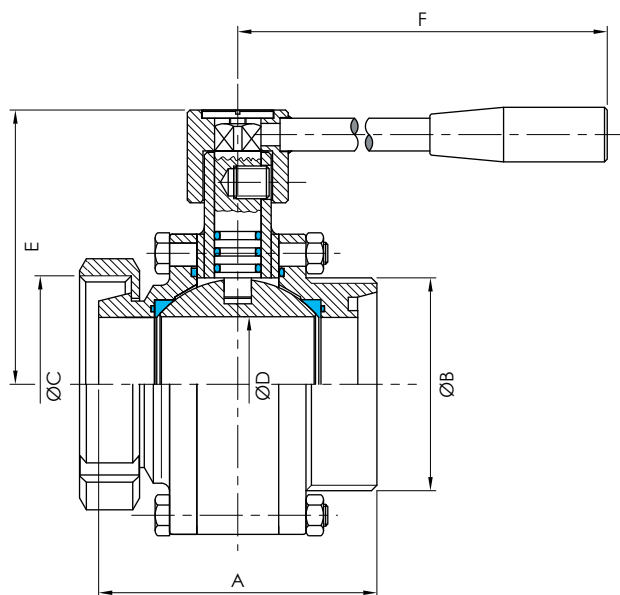



## Valvola a sfera K flangia- filetto DIN

K ball valve flange - DIN male end

K Kugelventil Flansch - DIN G

Vanne à boule K bride - mâle DIN

Válvula de bola K brida - macho DIN

art. 54

AISI 304 - 316

DN	A	B	C	D	E	F	G	H	L
25	96	Rd52x1/6"	85	24	73.5	14	115	4	122
32	96	Rd58x1/6"	100	33	79	18	140	4	122
40	110	Rd65x1/6"	110	40	95	18	150	4	180
50	110	Rd78x1/6"	125	49.5	100.5	18	165	4	180
60	124	Rd84.5x1/6"	145	57.5	107.25	18	185	4	205
65	124	Rd95x1/6"	145	65.5	125.5	18	185	4	266
80	162	Rd110x1/4"	160	79	136.5	18	200	4	266
100R	216	Rd130x1/4"	180	89	144.5	18	220	8	266

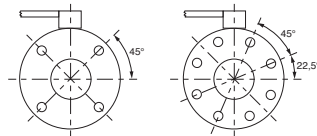

Posizione dei fori flangia rispetto alla valvola  
Position of the flange holes welded to the valve

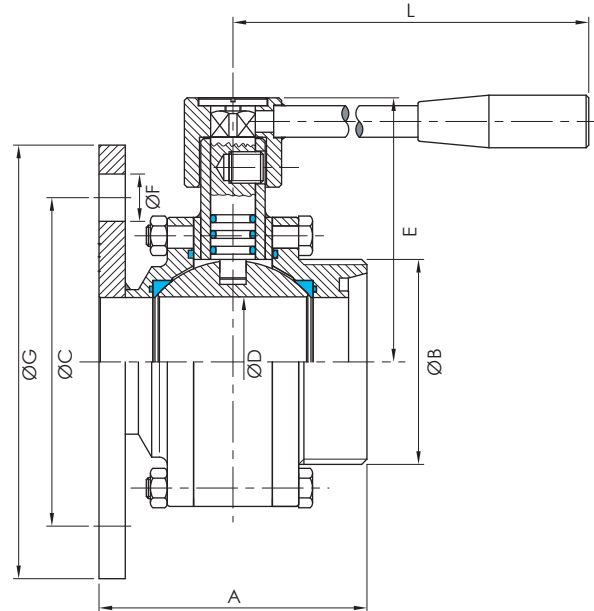

## Valvola a sfera K a saldare DIN

K ball valve welding ends

K Kugelventil DIN S/S

Vanne à boule K bouts lisses DIN

Válvula de bola K soldar DIN

art. 55

AISI 304 - 316

DN	A	B	C	D	E	F
25	88	31	31	24	73.5	122
32	88	37	37	33	79	122
40	102	43	43	40	95	180
50	102	55	55	49.5	100.5	180
60	114	63	63	57.5	107.25	205
65	124	72	72	65.5	125.5	266
80	152	87	87	79	136.5	266
100R	154	101.6	101.6	89	144.5	266

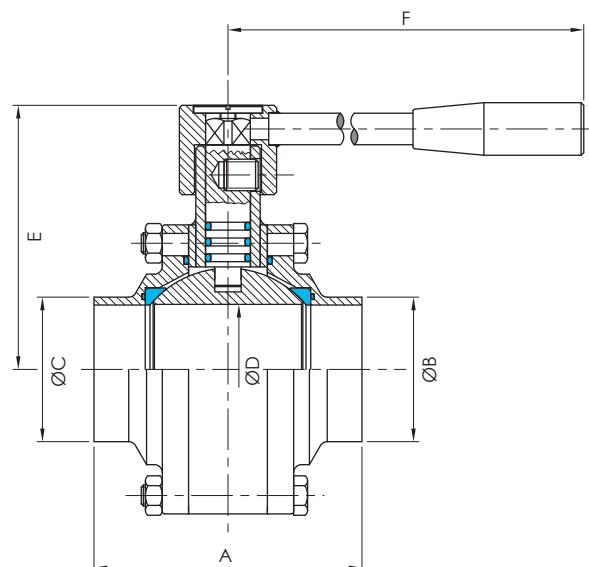

## Valvola a sfera K attacchi clamp

K ball valve ferrule ends

K Kugelventil Clamp Anschluß

Vanne à boule K bouts clamp

Válvula de bola K clamp

art. 59

AISI 304 - 316

DN	A	B	C	D	E	F
25	88	50.4	22.2	24	73.5	122
38	102	50.4	34.9	40	95	180
51	102	63.9	47.5	49.5	100.5	180
63	114	77.4	60.2	57.5	125.5	266
76	114	90.9	72.9	69	136.5	266
100R	206	118.9	89	89	144.5	266

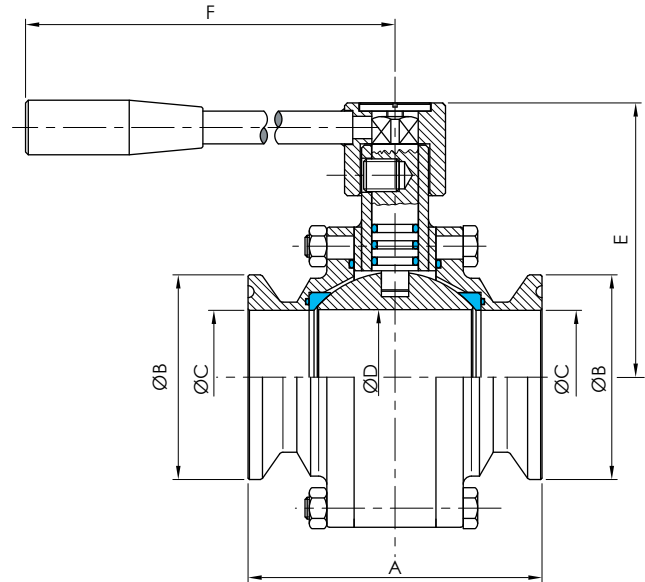

Ver. 04.18

## Valvola a sfera K saldare - clamp

K ball valve welding end - clamp ferrule

K Kugelventil S - Clamp

Vanne à boule K bout lisse - clamp

Válvula de bola K soldar - clamp

art. 60

AISI 304 - 316

DN	A	B	C	D	E	F
25	88	50.4	25.4	24	73.5	122
38	102	50.4	38.1	40	95	180
51	102	63.9	50.8	49.5	100.5	180
63	114	77.4	63.5	57.5	125.5	266
76	114	90.9	76.2	69	136.5	266
100R	206	118.9	101.6	89	144.5	266

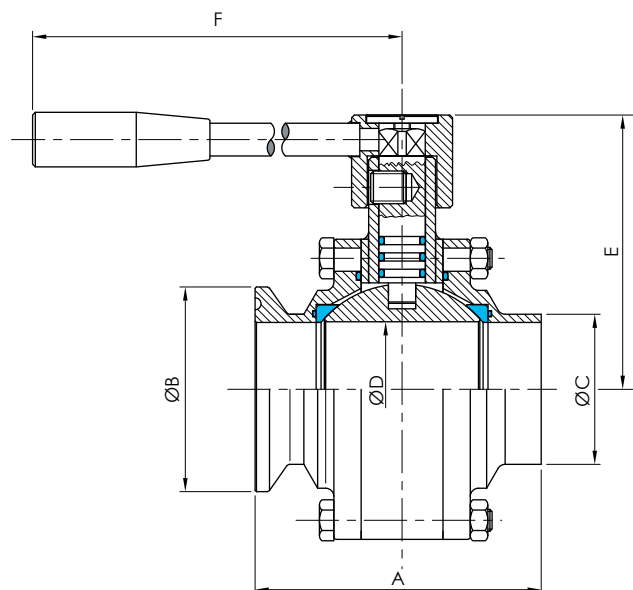

## Valvola a sfera K flangia quadra - Macon

K ball valve square flange - Macon male end

K Kugelventil Quadratflansch - Macon G

Vanne à boule K bride carrée - mâle Macon

Válvula de bola K brida cuadrada - macho Macon

AISI 304 - 316

 art. **70**

DN	A	B	C	D	E	F	G	H Nr. FORI	L
40	110	M55x3	75	40	95	11	100	4	180
50	110	M67x3	75	49.5	100.5	11	100	4	180
60	124	M79x3.5	82	57.5	107.25	13	120	4	205
70	124	M90x3.5	90	69	125.5	13	120	4	266
80	162	M102x4	102.5	79	136.5	13	140	4	266
100R	216	M125x4	102.5	89	144	13	140	4	266

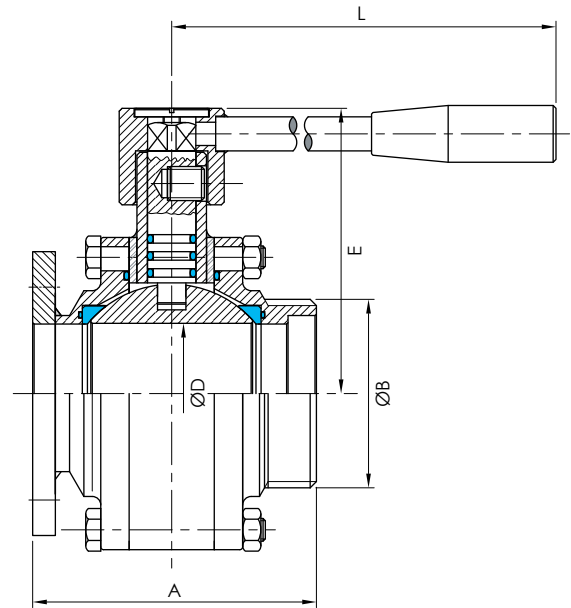
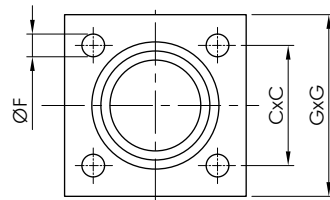

## Valvola a sfera K maschio girella macon - filetto macon

K ball valve Macon nut and liner - male end

K Kugelventil Macon KM/G

Vanne à boule K mâle - femelle macon

Válvula de bola K tuerca macon - macho macon

AISI 304 - 316

 art. **73**

DN	A	B	C	D	E	L
40	102	55x3	40	95	180	180
50	102	67x3	49.5	100.5	180	180
60	114	79x3.5	57.5	107.25	205	205
70	124	90x3.5	69	125.5	266	266
80	152	102x4	79	136.5	266	266
100R	154	125x4	89	144	266	266

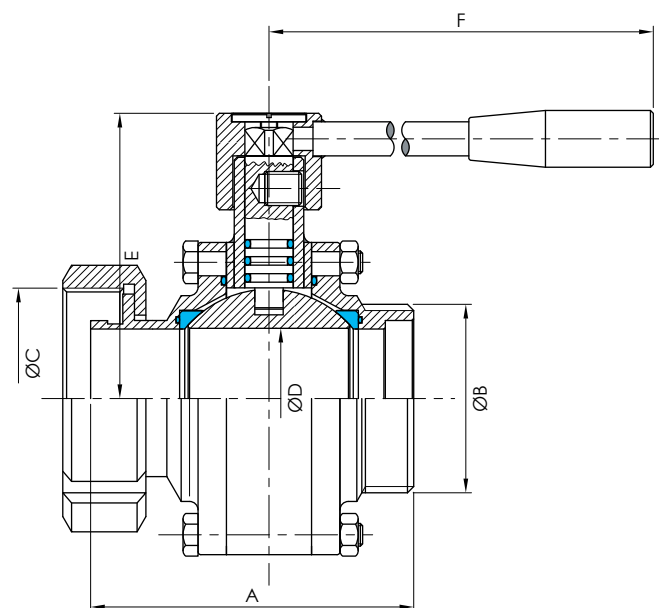

## Valvola a sfera K flangia - garolla

K ball valve flange - garolla end

K Kugelventil Flansch - Garolla Anschluß

Vanne à boule K bride - garolla

Válvula de bola K brida - garolla

AISI 304 - 316

DN	A	B	C	D	E	F	G	H	L
40	110	65	110	40	95	18	150	4	180
50	110	76	125	49.5	100.5	18	165	4	180
60	124	87	145	57.5	107.25	18	185	4	205
70	124	97	160	69	125.5	18	200	4	266
80	162	108	160	79	136.5	18	200	4	266
100R	216	129	180	89	144.5	18	220	8	266

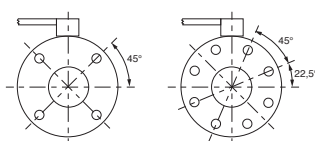

Posizione dei fori flangia rispetto alla valvola  
Position of the flange holes welded to the valve

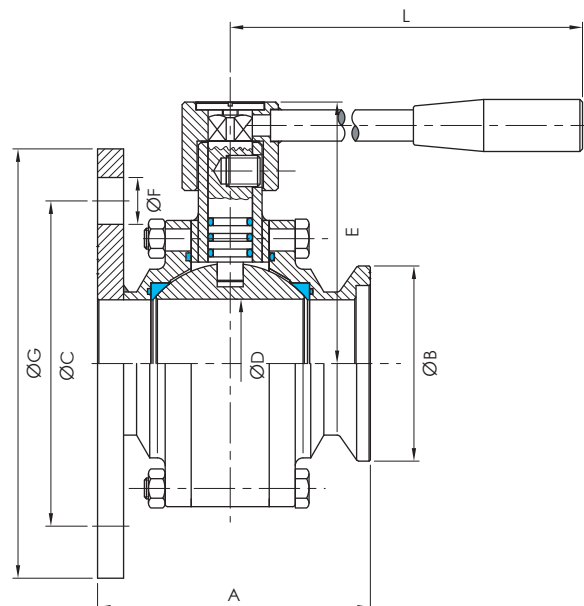

## Valvola a sfera K attacchi garolla

K ball valve garolla ends

K Kugelventil Garolla - AnschluÙe

Vanne à boule K DIN femelle - garolla

Válvula de bola K tuerca DIN - garolla

AISI 304 - 316

DN	A	B	D	E	F
40	102	65	40	95	180
50	102	76	49.5	100.5	180
60	114	87	57.5	107.25	205
70	124	97	69	125.5	266
80	152	108	79	136.5	266
100R	154	129	89	144.5	266

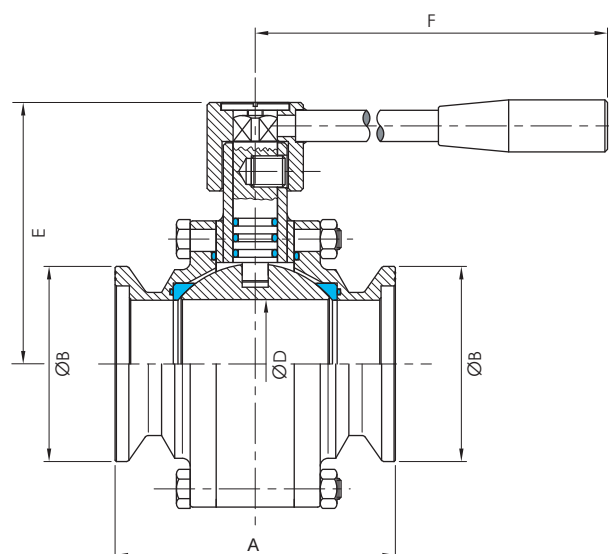

## Valvola a sfera K flangia per cemento - garolla

K ball valve reduced for cementing flange - garolla

K Kugelventil Flanschansatz für Betonfässer - Garolla

Vanne à boule K bride pour béton - garolla

Válvula de bola K brida por cemento - garolla

AISI 304 - 316

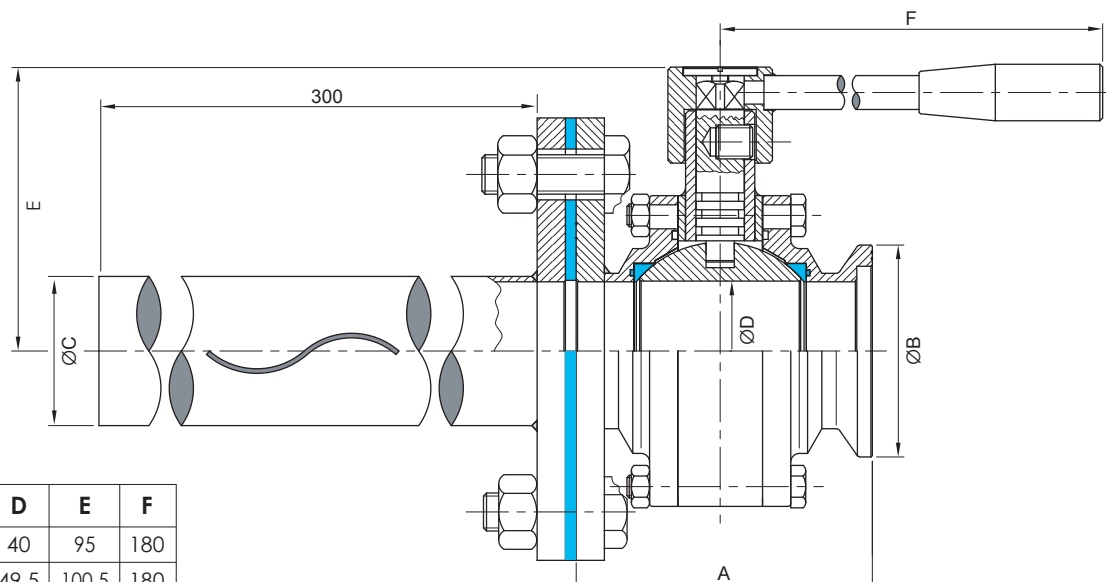

DN	A	B	C	D	E	F
40	110	65	42	40	95	180
50	110	76	52	49.5	100.5	180
60	124	87	63	57.5	107.3	205
70	124	97	76	69	125.5	266
80	162	108	85	79	136.5	266
100R	216	129	101.6	89	144	266

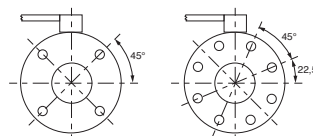

Posizione dei fori flangia rispetto alla valvola  
Position of the flange holes welded to the valve

## Valvola a sfera K maschio girella DIN - garolla

K ball valve DIN nut and liner - garolla end

K Kugelventil DIN KM - Garolla

Vanne à boule K DIN femelle - garolla

Válvula de bola K tuerca DIN - garolla

AISI 304 - 316

DN	A	B	C	D	E	F
40	102	65	65x1/6"	40	95	180
50	102	76	78x1/6"	49.5	100.5	180
60	114	87	84.5x1/6"	57.5	107.25	205
70	124	97	95x1/6"	69	125.5	266
80	152	108	110x1/4"	79	136.5	266
100R	154	129	130x1/4"	89	144	266

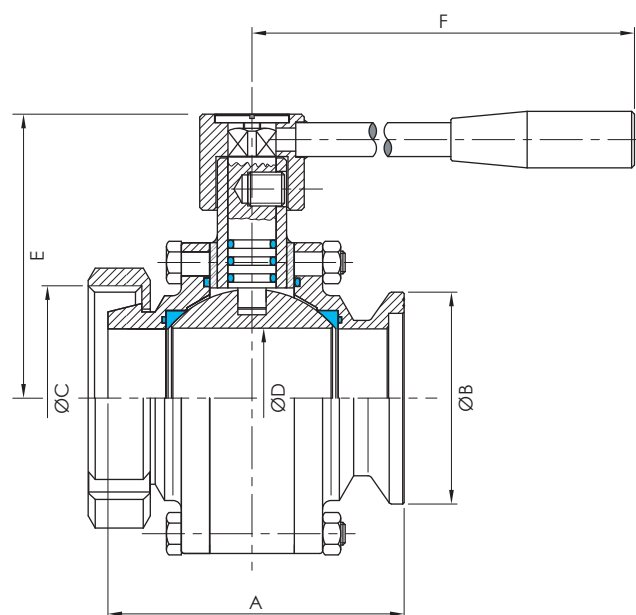

## Kit guarnizioni di ricambio valvole K

K ball valve seal kit

Ersatz-Dichtungen für K Kugelventile

Kit joints de rechange pour vanne K

Kit juntas de repuesto válvulas K

art. **79L**

POS.	DENOMINAZIONE	PART NAME	MATERIALE - MATERIAL
7	SEDE SFERA	BALL SEAT	P.T.F.E / P.T.F.E. VETRO
8	OR CUFFIA	CAP OR	EPDM / NBR / SILICONE / VITON
9	OR PERNO	PIN OR	EPDM / NBR / SILICONE / VITON

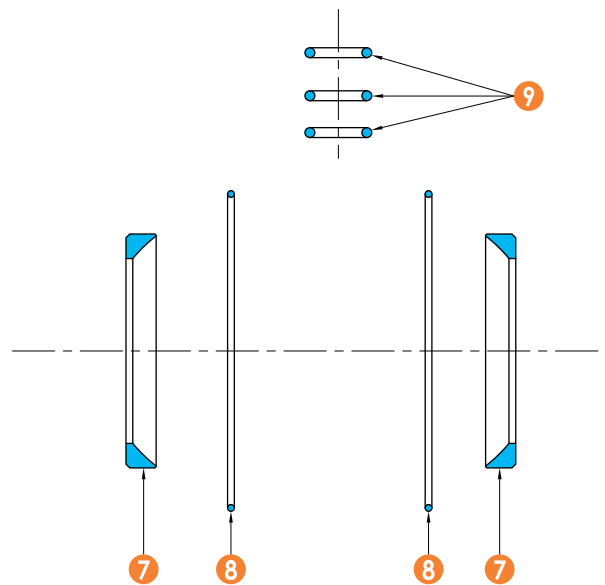

Ver. 04.18

## Maniglia inox valvola K

Stainless Steel handle for K valve

Edelstahl Griff für K Ventil

Poignée inox pour vanne K

Mando inox por válvula K

art. **79M**

AISI 304

TIPO	A	B	C	D	E	F
01	28	28	122	55	10	18
02	37	34	180	65	12	20
03	54	41	266	90	15	25

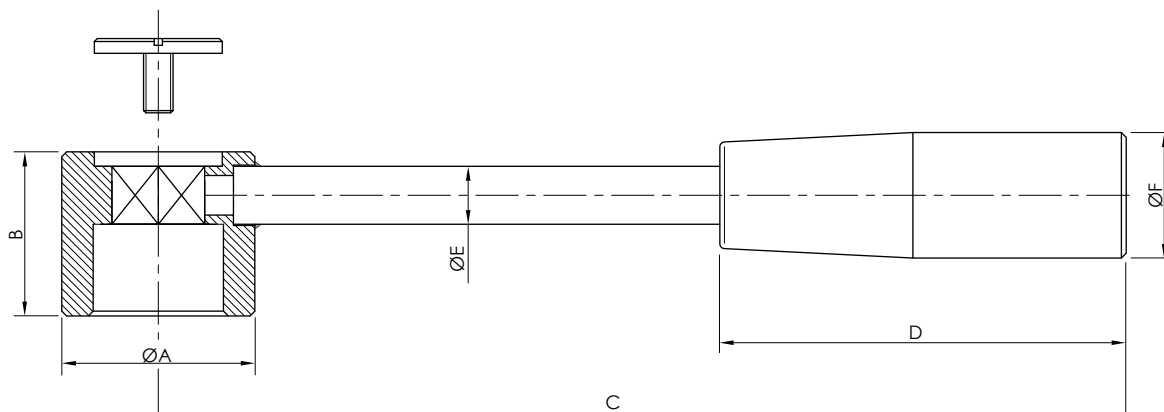

Le informazioni contenute in questo documento sono puramente indicative e non impegnative, l'azienda si riserva il diritto di modificarle senza obbligo di preavviso.  
The informations provided in this document are intended for informational purposes only and are subject to change without notice.





**VALVOLE A SFERA**  
Ball valves  
Kugelventile  
Vannes à boule  
Válvulas de bola

**RS**



## VALVOLE A SFERA RS

Le nostre valvole tipo RS sono progettate per soddisfare le pressanti esigenze della clientela che chiede un prodotto alternativo economico. Questo obiettivo è stato raggiunto senza rinunciare alla qualità, requisito indispensabile per il mercato. Il contenimento dei costi è stato possibile grazie ad alcune modifiche tecniche: la saldatura del raccordo direttamente sul corpo valvola che ne evita così il possibile svitamento, cosa che può accadere alle valvole a 3 corpi avvitati presenti sul mercato, e la scelta di una nuova maniglia di facile costruzione.

**CAMPO D'IMPIEGO:** serbatoi, macchine, impianti e apparecchi a bassa pressione.

**Tutti i materiali usati sono compatibili per il contatto con alimenti in accordo al Reg. (CE) n.1935/2004 - D.M. 21/03/1973 e FDA, 21 CFR.**

## BALL VALVES RS

Our RS valves type has been projected to satisfy the pressing custom demands of an alternative and economic product. Despite of this, Veneta Acciai absolutely did not give up the quality, prerequisite for its own market. The solution that has allowed Veneta Acciai to contain the costs to the minimum, has been to weld the fitting directly on the body valve, and the choose of an easy assembling handle. This device has also allowed to get greater safety, because the possible unscrewing that can happen on the three-screwed body valves is completely avoided.

**FIELDS OF APPLICATION:** tanks, machinery, fittings and low pressure equipment.

**All materials used are suitable for food contact according to the European Regulation EC 1935/2004 - FDA.**

## KUGELVENTILE RS

Unsere Ventile Typ RS wurde entworfen, um den dringenden Anforderungen der Kundschaft nach einem billigeren Produkt entgegenzukommen. Die Firma Veneta Acciai hat hiermit allerdings nicht auf die Qualität verzichtet, die ein der unentbehrlichen Erfordernissen für eigenen Markt darstellt. Die Lösung, die hat erlaubt, die Kosten am meisten einzuschränken, war jenes, die Hinterklappe direkt auf dem Ventilkörper zu schweißen. Diese Lösung hat weiters erlaubt, eine größere Sicherheit zu erzielen, weil sie eine mögliche Ausschraubung vermieden hat, im Vergleich zu den Dreikörper-Ventilen auf dem Markt. In der neuen Lösung ist auch ein einfacher Handgriff eingeschlossen, den man leicht herstellen kann.

**EINSATZBEREICHE:** Behälter, Maschinen, Tiefdruckanlagen und Geräte.

**Alle verwendeten Materialien sind mit Kontakt mit Lebensmitteln vereinbar, in Übereinstimmung mit der europäischen Verordnung (EG) Nr 1935/2004 - FDA.**

### CARATTERISTICHE TECNICHE

- Costruita da pezzi forgiati AISI 304L/316L
- Corpo da tubo di grosso spessore
- Organo di comando a leva apertura a 180° o servocomandata elettricamente e ad aria
- Guarnizioni in PTFE
- Sfera AISI 304/316L
- Passaggio totale
- Connessioni standard DIN/Clamp/ SMS/GAS, Eno/Macon e a richiesta
- Fluidi di gruppo 2
- Finitura standard Ra ≈ 1
- Produzione standard da DN 10 a DN 150
- Pressione di esercizio da DN 10/50 PN16 da DN 60/100 PN10, da DN 125/150 PN6
- Temperatura da 0°C +120°C
- \* Per temperatura minore a 0°C utilizzare sistema KTP pag.115
- Collaudo al 100%

## VANNES À BOULE RS

Nos vannes type RS ont été conçues pour répondre aux exigences insistantes de la clientèle, qui demande un produit alternatif économique. Mais la société Veneta Acciai n'a absolument pas pour autant renoncé à la qualité, condition requise essentielle pour satisfaire son marché. Les solutions qui ont permis de limiter les prix au minimum ont été de choisir une poignée simple et de fabrication facile et de souder directement le raccord arrière sur le corps de la vanne, cette solution ayant aussi permis d'obtenir une plus grande sécurité car elle évite le dévissage possible par rapport aux vannes à 3 corps vissés présentes sur le marché.

**DOMAINES D'UTILISATION:** réservoirs, machines, installations et appareils à basse pression.

**Tous les matériaux utilisés sont compatibles avec le contact alimentaire conformément au règlement européen (CE) No 1935/2004 - FDA.**

## VALVULAS DE BOLA RS

Nuestras válvulas tipo RS han sido diseñadas para satisfacer las acuciantes exigencias de la clientela que solicita una alternativa de producto económico. Esto ha impulsado Veneta Acciai a no renunciar absolutamente a la calidad, requisito indispensable para el propio mercado.

Las soluciones que han permitido mantener al mínimo los costes consisten en optar por una maneta sencilla y de fácil fabricación y soldar directamente en el cuerpo de la válvula la conexión trasera, solución que ha permitido obtener una mayor seguridad porque previene que se desenrosque en comparación con las válvulas de 3 cuerpos enroscados disponibles en el mercado.

**APLICACIONES:** depósitos, máquina, instalaciones y equipos a baja presión.

**Todos los materiales utilizados son compatibles para el contacto con alimentos según la normativa europea (CE) n. 1935/2004 - FDA.**

### TECHNICAL DATA

- Built by forged pieces AISI 304L/316L
- Body made from thick tube
- Opening by 180° lever or by electrical or pneumatic actuators
- Gaskets in PTFE
- Ball 304/316L
- Full bore
- Standard connections DIN/Clamp / SMS/GAS Eno/Macon and on request
- Fluid of group 2
- Standard finish Ra ≈ 1
- Standard production from DN 10 to DN 150
- Pressure of working from DN 10/50 PN16, from DN 60/100 PN10, from DN 125/150 PN6
- Temperature from 0°C to +120°C
- \* For lower temperature at 0°C use KTP system page 115
- 100% Tested

Veneta Acciai Srl dichiara che i propri prodotti e i materiali sono idonei e adatti al luogo e al tipo di installazione inoltre sono testati con attrezzature speciali.

In accordo con la vigente Direttiva 2014/68/CE (PED) si riportano di seguito le condizioni di utilizzo in funzione alle dimensioni nominali (DN) delle valvole:

Veneta Acciai Srl declares that own products are perfectly made using proper material suitable for place and type of installation and tested with special equipments.

In accordance with the current Directive 2014/68/CE (PED) terms of use are reported below on the nominal dimensions (DN) of valves:

CLASSIFICAZIONE / CLASSIFICATION ( Allegato II / Annex II - 2014/68/CE )						
Tipo valvola Valve type	DN (mm)	PN ( bar)	Temperatura Temperature ( °C )	Gruppo fluido Fluid group	Categoria di rischio Risk category	Marchio CE CE mark
VALVOLE A SFERA Ball valves	10 + 50	16	-15 + 120	2	Art. 4.3	NO
	60 + 100	10	-15 + 120	2	Art. 4.3	NO
	125 + 150	6	-15 + 120	2	Art. 4.3	NO

Le informazioni contenute in questo documento sono puramente indicative e non impegnative, l'azienda si riserva il diritto di modificarle senza obbligo di preavviso.

The informations provided in this document are intended for informational purposes only and are subject to change without notice.

**VALVOLE A SFERA**  
 BALL VALVES  
 KUGELVENTILE  
 VANNES À BOULE  
 VALLVULAS DE BOLA

# RS

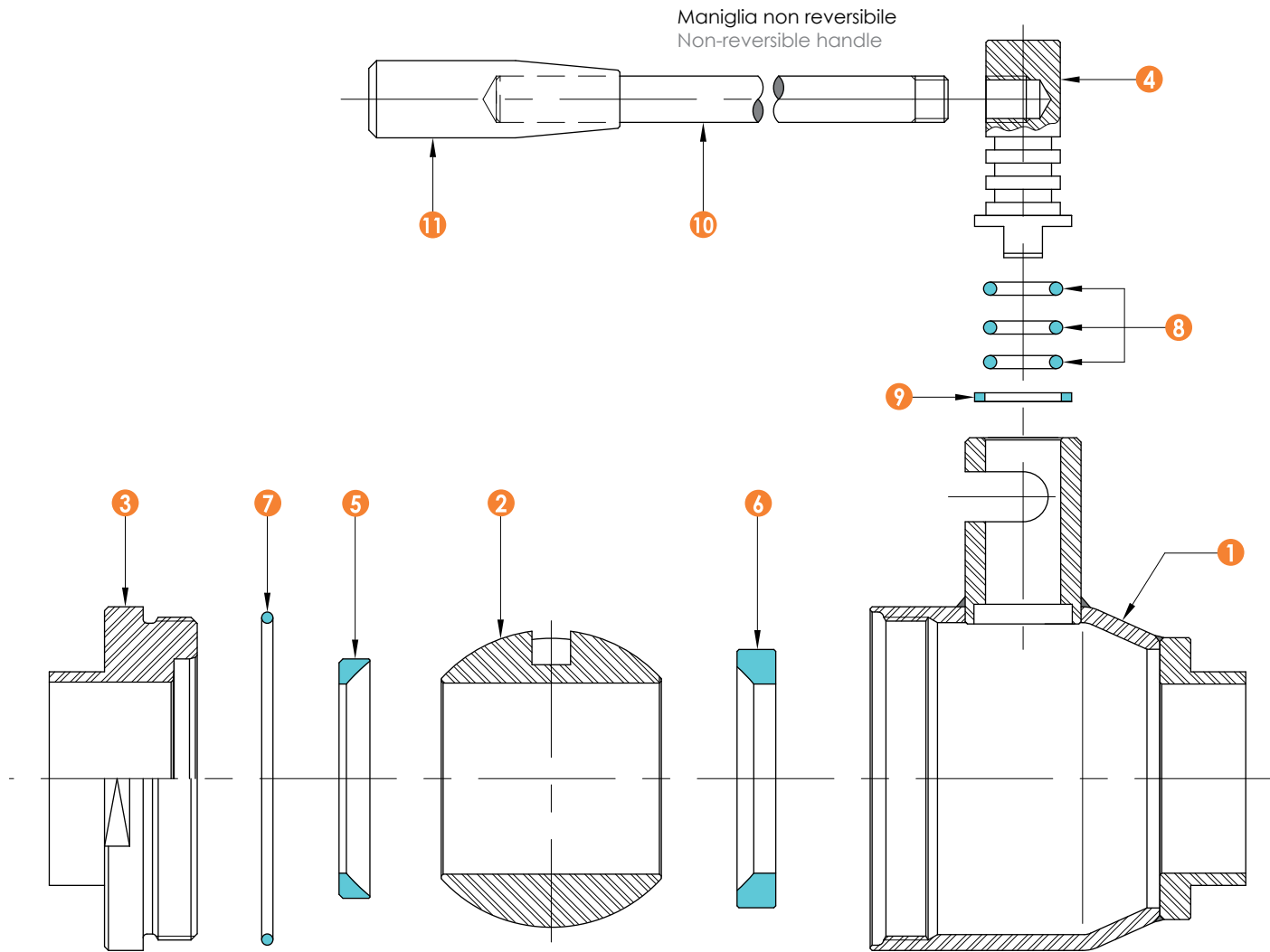

POS.	DENOMINAZIONE	PART NAME	MAT.
1	CORPO VALVOLA	BODY VALVE	AISI 304/316
2	SFERA	BALL	AISI 304/316
3	CUFFIA	CAP	AISI 304/316
4	PERNO	PIN	AISI 304/316
5	SEDE SFERA	BALL SEAT	P.T.F.E Caricato vetro / Glass filled
6	SEDE SFERA	BALL SEAT	P.T.F.E
7	OR CUFFIA	CAP OR	EPDM
8	OR PERNO	PIN OR	EPDM
9	GUARNIZIONE PERNO	PIN JOINT	P.T.F.E.
10	ASTA MANIGLIA, Apertura 180°	HANDLE SHAFT, 180° opening	AISI 304
11	TERMINALE MANIGLIA	HANDLE	AISI 304

## Schema di montaggio valvole RS con attuatore

Mounting drawing with RS Ball Valve Actuator

Montage-Zeichnung mit RS Ventiltrieb

Schéma de montage vanne a boule RS avec verin pneumatique

Esquema de montaje válvula de bola RS con neumático

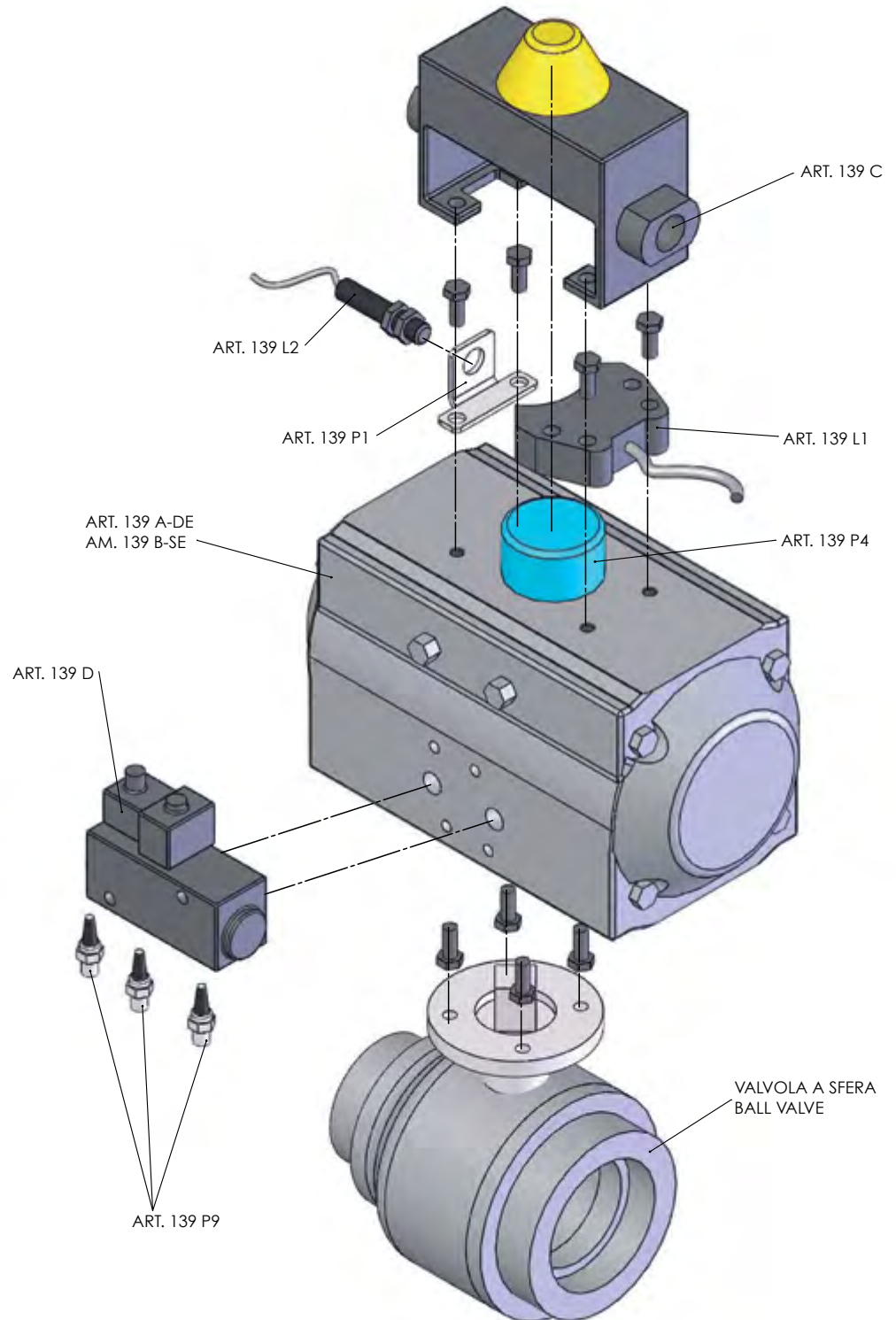

## Valvola a sfera RS attacchi filettati SMS

art. 80

RS ball valve SMS male ends

RS Kugelventil SMS G/G

Vanne à boule RS bouts filetés SMS

Válvula de bola RS macho - macho SMS

DN	A	B	C	D	E	F
25	86	40x1/6"	24	44	146	
38	127	60x1/6"	35	64	185	
51	137	70x1/6"	49.5	68	185	
63	161	85x1/6"	57.5	73	205	
76	180	98x1/6"	69	95	243	
104	204	125x1/6"	99	122	273	

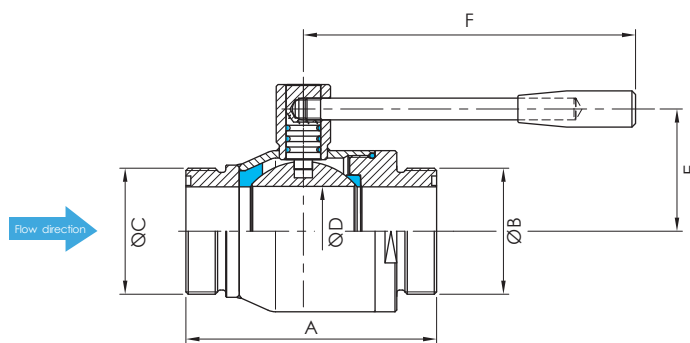

## Valvola a sfera RS maschio girella SMS - filetto SMS

art. 80A

RS ball valve SMS nut and liner - male end

RS Kugelventil SMS KM/G

Vanne à boule RS mâle - femelle SMS

Válvula de bola RS tuerca - macho SMS

DN	A	B	C	D	E	F
25	86	40x1/6"	24	44	146	
38	127	60x1/6"	35	64	185	
51	137	70x1/6"	49.5	68	185	
63	161	85x1/6"	57.5	73	205	
76	180	98x1/6"	69	95	243	
104	204	125x1/6"	99	122	273	

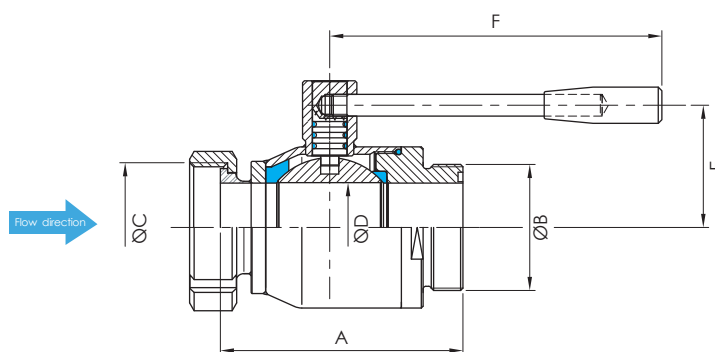

## Valvola a sfera RS flangia - filetto SMS

art. 80B

RS ball valve flange SMS male end

RS Kugelventil Flansch - SMS G

Vanne à boule RS bride - bout fileté SMS

Válvula de bola RS brida - macho SMS

DN	A	B	C	D	E	F	G	H	L
25	72	40x1/6"	85	24	44	14	115	4	146
38	107	60x1/6"	110	35	64	18	150	4	185
51	117	70x1/6"	125	49.5	68	18	165	4	185
63	141	85x1/6"	145	57.5	73	18	185	4	205
76	156	98x1/6"	160	69	95	18	200	4	243
104	181	125x1/6"	180	99	122	18	220	8	273

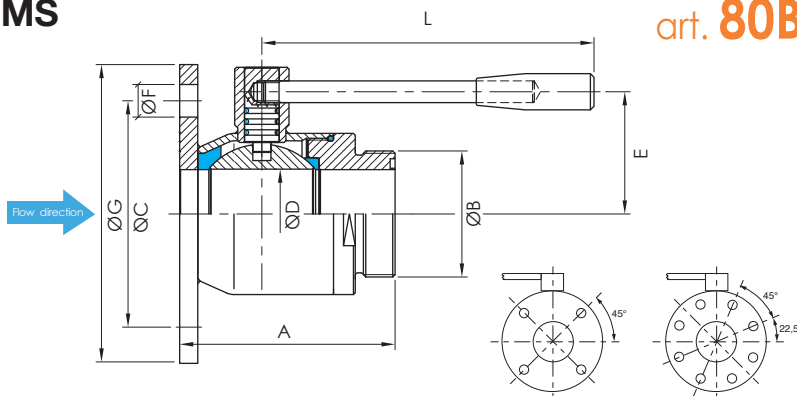

Posizione dei fori flangia rispetto alla valvola  
Position of the flange holes welded to the valve

## Valvola a sfera RS a saldare SMS

art. 80C

RS ball valve welding ends

RS Kugelventil SMS S/S

Vanne à boule RS bouts lisses

Válvula de bola RS soldar SMS

DN	A	B	C	D	E	F
25	86	28	28	24	44	146
38	127	38	38	35	64	185
51	137	51	51	49.5	68	185
63	161	64	64	57.5	73	205
76	180	76.5	76.5	69	95	243
104	204	104	104	99	122	273

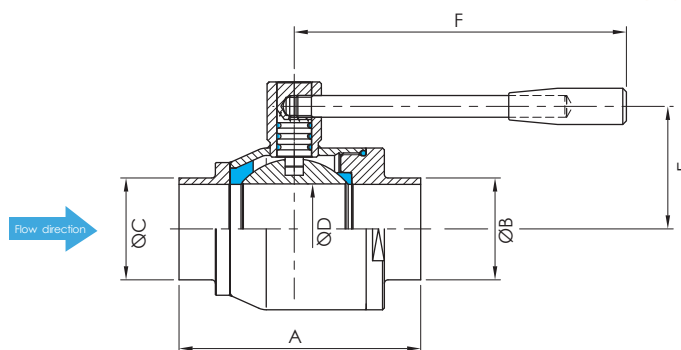

## Valvola a sfera RS con attacchi filettati DIN

RS ball valve DIN male ends

K Kugelventil DIN G/G

Vanne à boule K bouts filetés DIN

Válvula de bola K macho - macho DIN

art. 81

DN	A	B	C	D	E	F
25	97	52x1/6"		24	44	146
32	113	58x1/6"		33	50	146
40	127	65x1/6"		40	64	185
50	134	78x1/6"		49.5	68	185
60	150	84.5x1/6"		57.5	73	205
65	161	95x1/6"		69	95	243
80	180	110x1/4"		79	104	243
100	204	130x1/4"		99	122	273
125	225	160x1/4"		119	135	273
150	254	190x1/4"		136	148	273

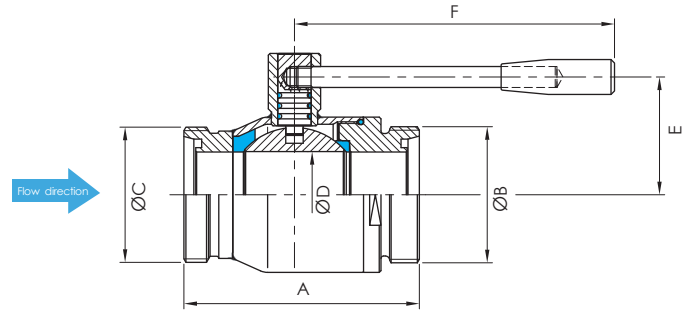

## Valvola a sfera RS maschio girella - filetto DIN

RS ball valve DIN nut and liner - male end

RS Kugelventil DIN KM/G

Vanne à boule RS mâle - femelle DIN

Válvula de bola RS tuerca - macho DIN

art. 81A

DN	A	B	C	D	E	F
25	92	52x1/6"		24	44	146
32	109	58x1/6"		33	50	146
40	127	65x1/6"		40	64	185
50	137	78x1/6"		49.5	68	185
60	150	84.5x1/6"		57.5	73	205
65	161	95x1/6"		69	95	243
80	180	110x1/4"		79	104	243
100	204	130x1/4"		99	122	273
125	225	160x1/4"		119	135	273
150	254	190x1/4"		136	148	273

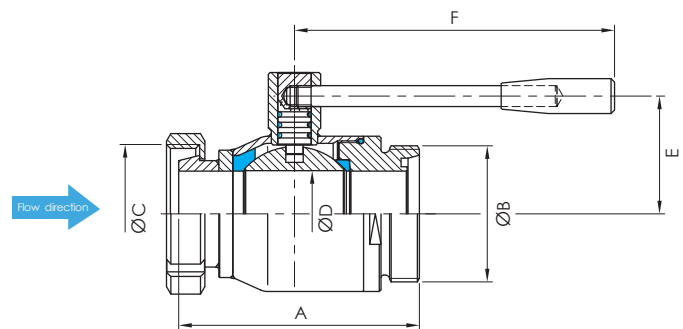

## Valvola a sfera RS flangia - filetto DIN

RS ball valve flange - DIN male end

RS Kugelventil Flansch - DIN G

Vanne à boule RS bride - bout fileté DIN

Válvula de bola RS brida - macho DIN

art. 81B

DN	A	B	C	D	E	F	G	H	L
25	72	52x1/6"	85	24	44	14	115	4	146
32	93	58x1/6"	100	33	50	18	140	4	146
40	107	65x1/6"	110	40	64	18	150	4	185
50	117	78x1/6"	125	49.5	68	18	165	4	185
60	130	84.5x1/6"	145	57.5	73	18	185	4	205
65	141	95x1/6"	145	69	95	18	185	4	243
80	156	110x1/4"	160	79	104	18	200	4	243
100	181	130x1/4"	180	99	122	18	220	8	273
125	201	160x1/4"	210	119	135	18	250	8	273
150	226	190x1/4"	240	136	148	22	285	8	273

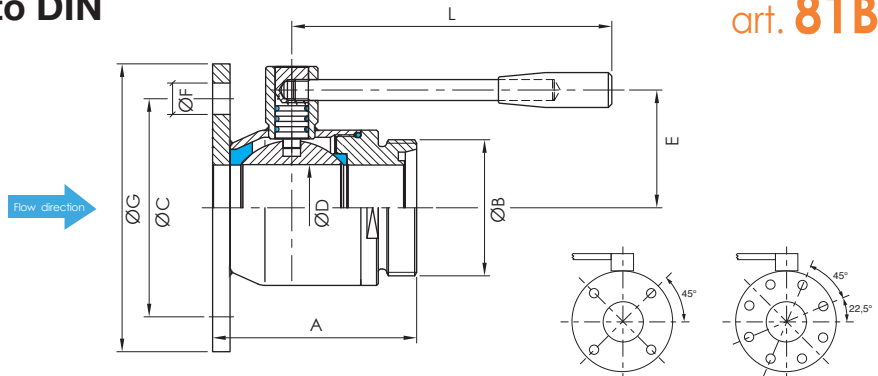

Posizione dei fori flangia rispetto alla valvola  
Position of the flange holes welded to the valve

## Valvola a sfera RS a saldare DIN

RS ball valve DIN welding ends

RS Kugelventil DIN S/S

Vanne à boule RS bouts lisses DIN

Válvula de bola RS soldar DIN

art. 81C

DN	A	B	C	D	E	F
15	86	21	16	16	40	90
20	86	25	20	20	40	90
25	86	31	26	24	44	117
32	109	37	32	33	50	146
40	124	43	38	40	64	185
50	135	55	50	49.5	68	185
60	148	63	57.5	57.5	73	205
65	161	72	66	69	95	243
80	180	87	81	79	104	243
100	204	106	100	99	122	273
125	225	132	125	119	135	273
150	246	154	146	136	148	273

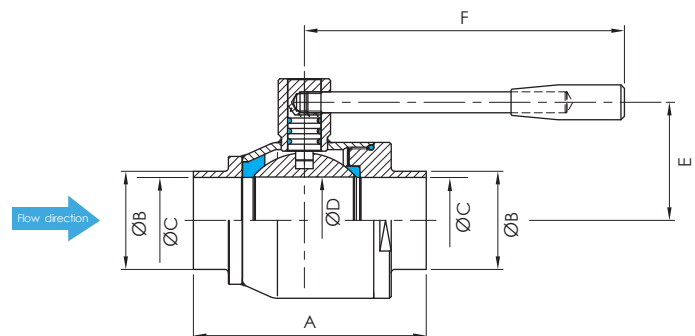

## Valvola a sfera RS femmina - femmina gas

RS ball valve ISO female threaded ends  
 RS Kugelventil ISO 2xInnengewinde  
 Vanne à boule RS filetage gaz fem - fem.  
 Válvula de bola RS hembra gas

art. 82

DN	A	B C	D	E	F
15	55	1/2"G	16	38	116
20	55	3/4"G	19	38	116
25	62	1"G	24	44	117
32	89	1 1/4"G	33	50	146
40	99	1 1/2"G	40	64	185
50	103	2"G	49.5	68	185
70	147	2 1/2"G	69	95	243
80	164	3"G	79	104	243
90	175	3 1/2"G	89	111	243
100	196	4"G	99	122	273
125	217	5"G	119	135	273
150	238	6"G	136	148	273

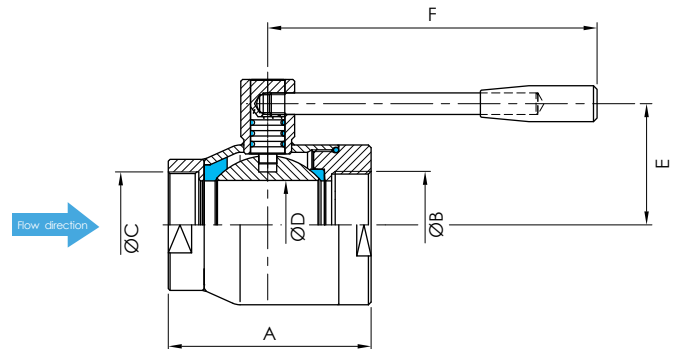

## Valvola a sfera RS maschio - maschio gas

RS ball valve ISO male threaded ends  
 RS Kugelventil ISO 2xAussengewinde  
 Vanne à boule RS filetage gaz mâle - mâle  
 Válvula de bola RS macho gas

art. 82A

DN	A	B C	D	E	F
15	79	1/2"G	16	38	116
20	79	3/4"G	19	38	116
25	86	1"G	24	44	117
32	109	1 1/4"G	33	50	146
40	127	1 1/2"G	40	64	185
50	137	2"G	49.5	68	185
70	161	2 1/2"G	69	95	243
80	180	3"G	79	104	243
90	187	3 1/2"G	89	111	243
100	204	4"G	99	122	273
125	225	5"G	119	135	273
150	246	6"G	136	148	273

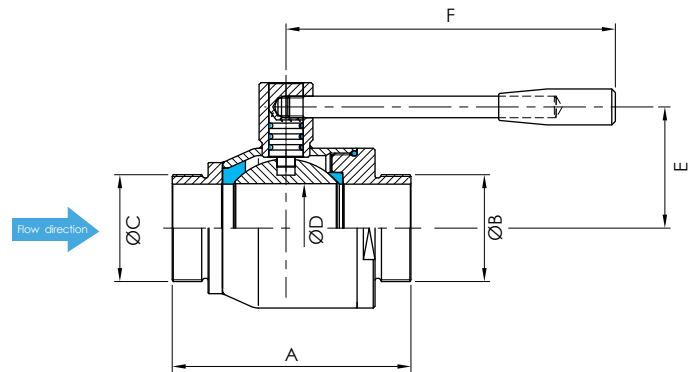

## Valvola a sfera RS femmina gas - maschio

RS ball valve ISO female - male threaded end  
 RS Kugelventil ISO weiblich x männlich Gewinde  
 Vanne à boule RS filetage gaz femelle - mâle  
 Válvula de bola RS hembra - macho gas

art. 82B

DN	A	B C	D	E	F
15	67	1/2"G	16	38	116
20	67	3/4"G	19	38	116
25	74	1"G	24	44	117
32	103	1 1/4"G	33	50	146
40	117	1 1/2"G	40	64	185
50	127	2"G	49.5	68	185
70	151	2 1/2"G	69	95	243
80	164	3"G	79	104	243
90	175	3 1/2"G	89	111	243
100	196	4"G	99	122	273
125	217	5"G	119	135	273
150	238	6"G	136	148	273

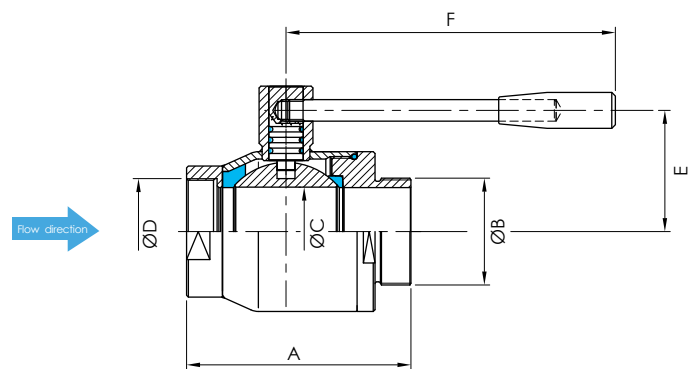

## Valvola a sfera RS flangia PN10 - femmina gas

art. **82C**

RS ball valve PN10 flange - ISO female threaded  
 RS Kugelventil PN10 Flansch - ISO Inn. Gewinde  
 Vanne à boule RS bride PN10 - femelle gaz  
 Válvula de bola RS brida PN10 - hembra gas

DN	A	B	C	D	E	F	G	H N° FORI	L
25	60	1"G	85	24	44	14	115	4	117
32	79	1¼"G	100	33	50	18	140	4	146
40	89	1½"G	110	40	64	18	150	4	185
50	103	2"G	125	49.5	68	18	165	4	185
70	137	2½"G	145	69	95	18	185	4	243
80	156	3"G	160	79	104	18	200	4	243
90	162	3½"G	180	89	111	18	220	8	243
100	181	4"G	180	99	122	18	220	8	273
125	201	5"G	210	119	135	18	250	8	273
150	222	6"G	240	136	148	22	285	8	273

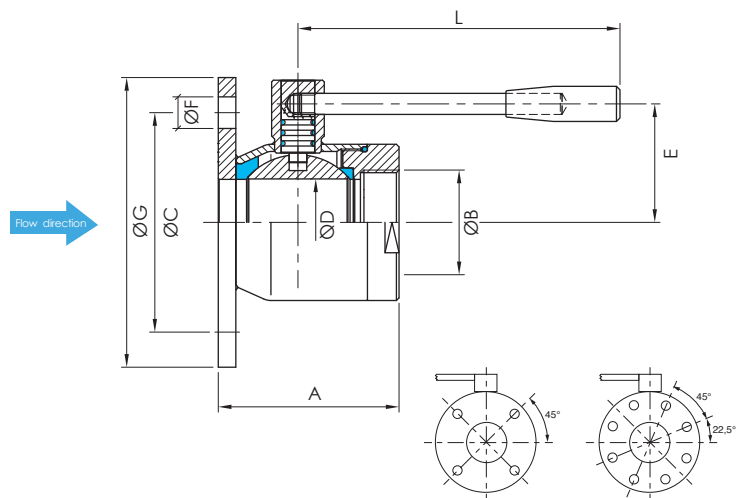

Posizione dei fori flangia rispetto alla valvola  
 Position of the flange holes welded to the valve

## Valvola a sfera RS flangia PN10 - maschio gas

art. **82D**

RS ball valve PN10 flange - ISO male threaded  
 RS Kugelventil PN10 Flansch - ISO Aus. Gewinde  
 Vanne à boule RS bride PN10 - mâle gaz  
 Válvula de bola RS brida PN10 - macho gas

DN	A	B	C	D	E	F	G	H N° FORI	L
25	72	1"G	85	24	44	14	115	4	117
32	93	1¼"G	100	33	50	18	140	4	146
40	107	1½"G	110	40	64	18	150	4	185
50	117	2"G	125	49.5	68	18	165	4	185
70	141	2½"G	145	69	95	18	185	4	243
80	156	3"G	160	79	104	18	200	4	243
90	162	3½"G	180	89	111	18	220	8	243
100	181	4"G	180	99	122	18	220	8	273
125	201	5"G	210	119	135	18	250	8	273
150	222	6"G	240	136	148	22	285	8	273

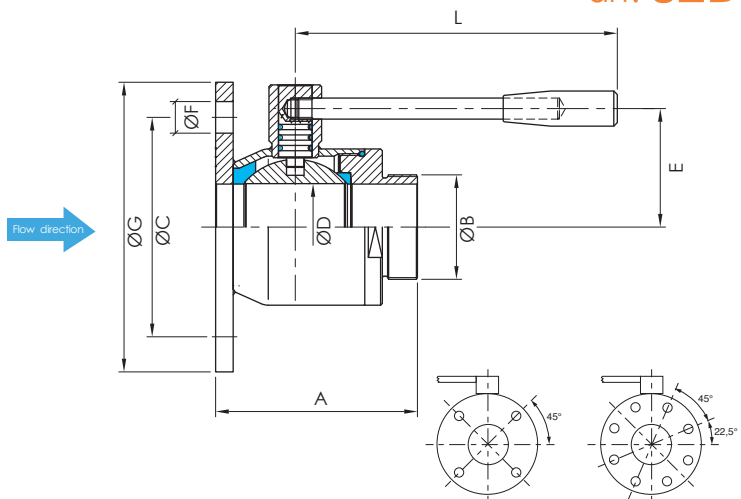

Posizione dei fori flangia rispetto alla valvola  
 Position of the flange holes welded to the valve

## Valvola a sfera RS flangia - flangia PN10

art. **82E**

RS ball valve - PN10 flange ends  
 RS Kugelventil 2xFlansch PN 10  
 Vanne à boule RS avec brides PN10  
 Válvula de bola RS con bridas PN10

DN	A	C	D	E	F	G	H N° FORI	L
25	80	85	24	55	14	115	4	117
32	101	100	33	70	18	140	4	146
40	115	110	40	92	18	150	4	185
50	125	125	49.5	95	18	165	4	185
70	142	145	69	122	18	185	4	243
80	164	160	79	130	18	200	4	243
90	169	180	89	140	18	220	8	243
100	189	180	99	150	18	220	8	273
125	209	210	119	190	18	250	8	273
150	230	240	136	211	22	285	8	273

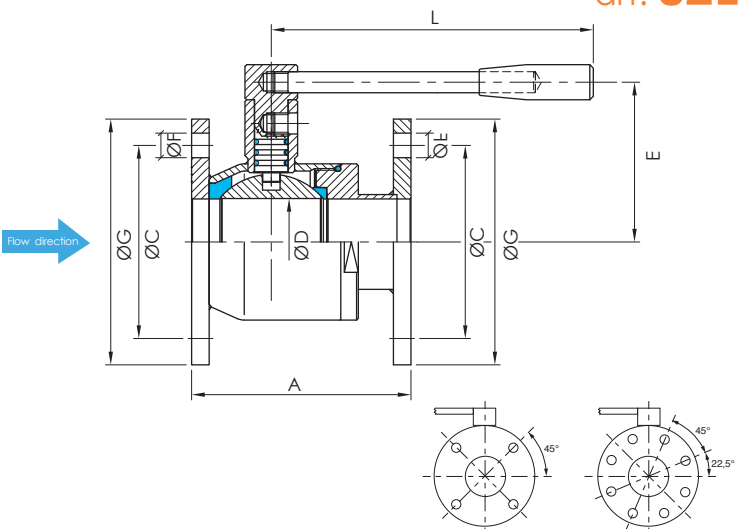

Posizione dei fori flangia rispetto alla valvola  
 Position of the flange holes welded to the valve

## Valvola a sfera RS femmina gas - garolla

RS ball valve ISO female threaded - garolla end

RS Kugelventil ISO Inn.Gew. - Garolla

Vanne à boule RS femelle gaz - garolla

Válvula de bola RS hembra gas - garolla

 art. **83**

DN	A	B	C	D	E	F
40	117	40	1¼"G	33	64	185
50	127	50	1½"G	40	68	185
60	139	60	2"G	49,5	73	205
70	151	70	2½"G	69	95	243
80	164	80	3"G	79	104	243
100R	187	100	3½"G	90	111	243
100	196	100	4"G	100	122	273
125	217	120	5"G	120	135	273
150	237	188	6"G	136	148	273

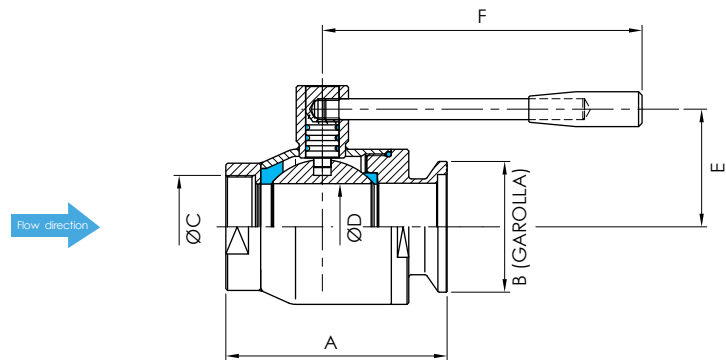

## Valvola a sfera RS maschio gas - garolla

RS ball valve ISO male threaded - garolla end

RS Kugelventil ISO Aus.Gew. - Garolla

Vanne à boule RS mâle gaz - garolla

Válvula de bola RS macho gas - garolla

 art. **83A**

DN	A	B	C	D	E	F
40	127	40	1¼"G	33	64	185
50	137	50	1½"G	40	68	185
60	150	60	2"G	50	73	205
70	161	70	2½"G	70	95	243
80	180	80	3"G	80	104	243
100R	187	100	3½"G	90	111	243
100	204	100	4"G	100	122	273
125	225	120	5"G	120	135	273
150	246	188	6"G	136	148	273

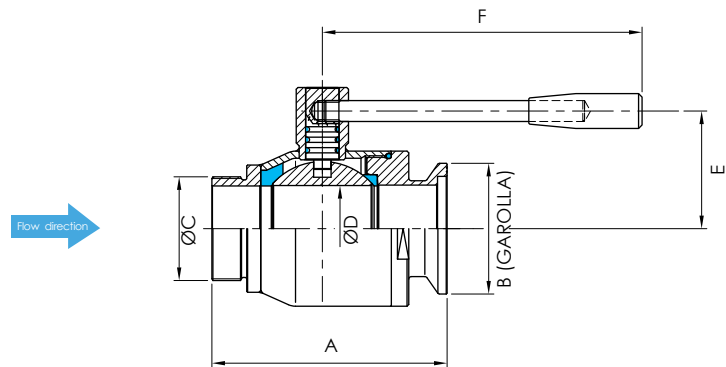

## Valvola a sfera RS garolla - garolla

RS ball valve garolla - garolla ends

RS Kugelventil Garolla AnschluÙe

Vanne à boule RS garolla - garolla

Válvula de bola RS garolla - garolla

 art. **83B**

DN	A	B	C	D	E	F
40	127	40	40	40	64	185
50	137	50	50	50	68	185
60	150	60	60	60	73	205
70	161	70	70	70	95	243
80	180	80	80	80	104	243
100R	187	100	100	90	111	243
100	204	100	100	100	122	273
125	225	120	120	120	135	273
150	246	188	188	136	148	273

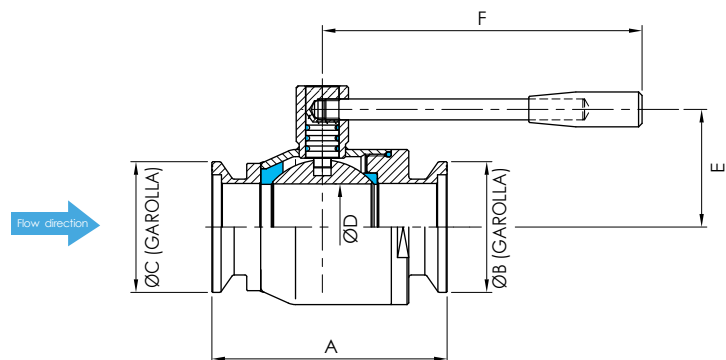



**Valvola a sfera RS maschio girella DIN - garolla**

RS ball valve DIN nut and liner - garolla end

RS Kugelventil DIN KM - Garolla

Vanne à boule RS femelle DIN - garolla

Válvula de bola RS tuerca DIN - garolla

DN	A	B	C	D	E	F
40	127	40	40	40	64	185
50	137	50	50	50	68	185
60	150	60	60	60	73	205
70	161	70	65	70	95	243
80	180	80	80	80	104	243
100R	187	100	100	90	111	243
100	204	100	100	100	122	273
125	225	120	125	120	135	273
150	246	188	190x1/4"	136	148	273

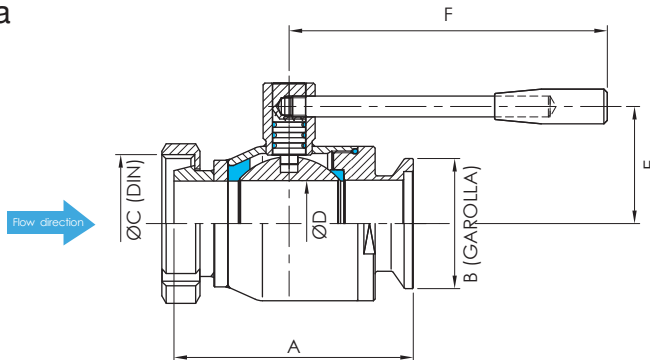

**Valvola a sfera RS flangia PN10 - garolla**

RS ball valve PN10 flange - garolla end

RS Kugelventil PN10 Flansch - Garolla

Vanne à boule RS bride PN10 - garolla

Válvula de bola RS brida PN10 - garolla

DN	A	B	C	D	E	F	G	H N° FORI	L
40	107	40	110	40	64	18	150	4	185
50	117	50	125	50	68	18	165	4	185
60	130	60	145	60	73	18	185	4	205
70	141	70	145	70	95	18	185	4	243
80	156	80	160	80	104	18	200	4	243
100R	162	100	160	90	104	18	200	4	243
100	181	100	180	100	122	18	220	8	273
125	201	120	210	120	135	18	250	8	273
150	222	188	240	136	148	22	285	8	273

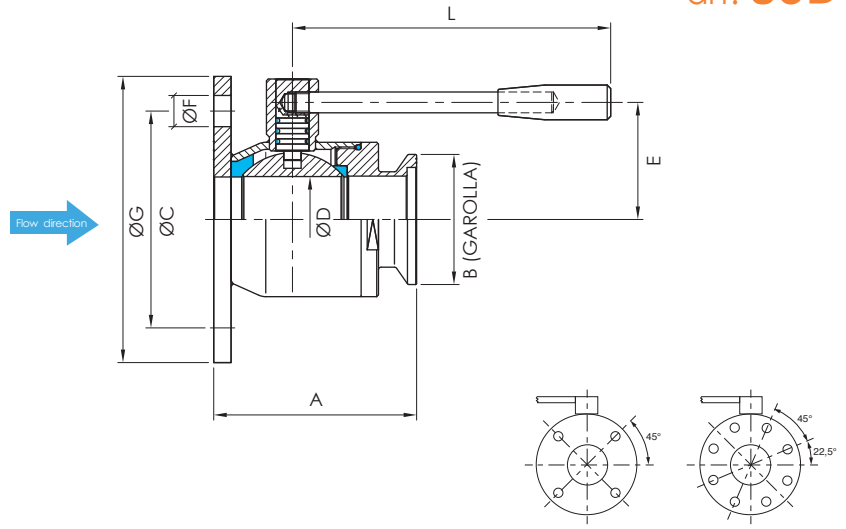

Posizione dei fori flangia rispetto alla valvola  
Position of the flange holes welded to the valve

**Valvola a sfera RS flangia per cemento - garolla**

RS ball valve reduced for cement flange - garolla end

RS Kugelventil Flanschansatz für Zement - Garolla

Vanne à boule RS bride pour béton - garolla

Válvula de bola brida por cemento - garolla

DN	A	B	C	D	E	F
40	107	40	42.4	40	64	185
50	117	50	60	50	68	185
60	130	60	63	60	73	205
70	141	70	76.1	70	95	243
80	156	80	88.9	80	104	243
100R	162	100	101.6	90	104	243
100	181	100	104	100	122	273
125	201	120	129	120	135	273
150	222	188	154	136	148	273

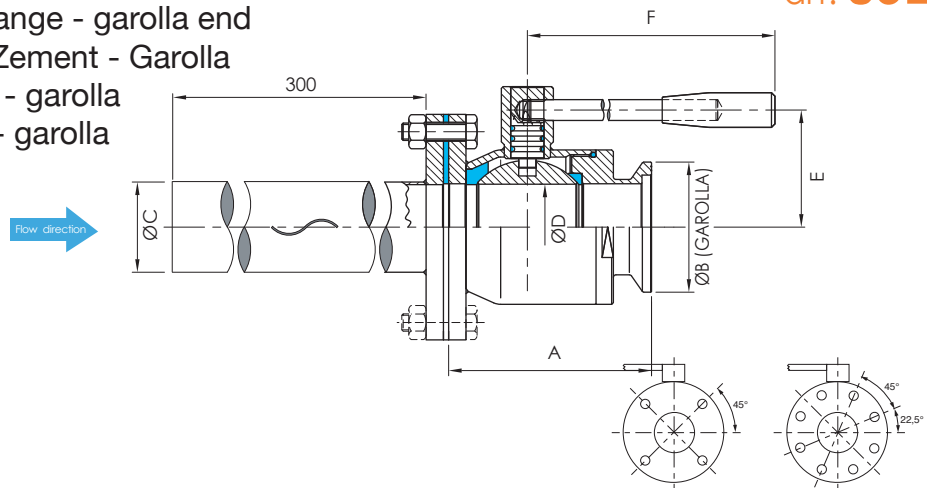

Posizione dei fori flangia rispetto alla valvola  
Position of the flange holes welded to the valve

## Valvola a sfera RS flangia quadra - macon

RS ball valve square flange - Macon male end

RS Kugelventil Quadratflansch - Macon G

Vanne à boule RS bride carrée - mâle macon

Válvula de bola RS brida cuadrada - macho macon

DN	A	B	C	D	E	F	G	H Nr. FORI	L
40	107	55x3	75	40	64	11	100	4	185
50	117	67x3	75	50	68	11	100	4	185
60	130	79x3.5	82	60	73	13	120	4	205
70	141	90x3.5	90	70	95	13	120	4	243
80	156	102x4	102.5	80	104	13	140	4	243
100	181	125x4	102.5	100	122	13	140	4	273
125	201	146x4	102.5	117	135	13	140	4	273

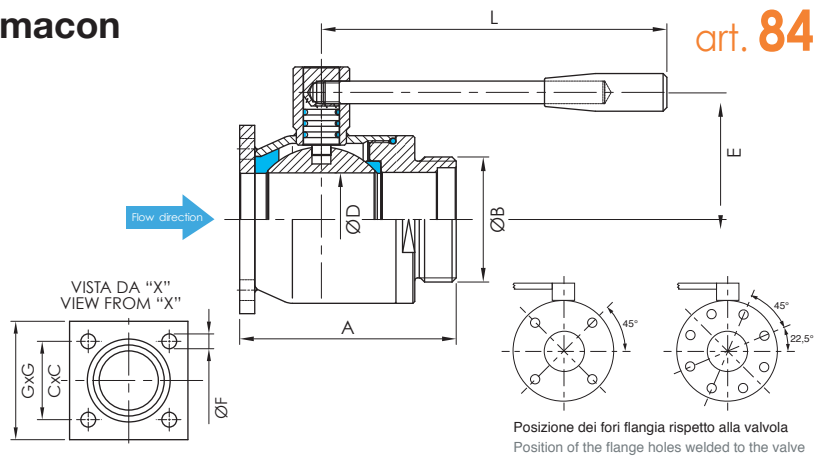

art. 84

## Valvola a sfera RS femm.gas - macon

RS ball valve BSP fem. threaded - macon male end

RS Kugelventil BSP Inn. Gew. - macon

Vanne à boule RS femelle gaz - mâle macon

Válvula de bola RS hembra gas - macho macon

DN	A	B	C	D	E	F
40	117	55x3	1½"G	40	64	185
50	127	67x3	2"G	50	68	185
70	151	90x3.5	2½"G	70	95	243
80	164	102x4	3"G	80	104	243
100	196	125x4	4"G	100	122	273
125	217	146x4	5"G	117	135	273

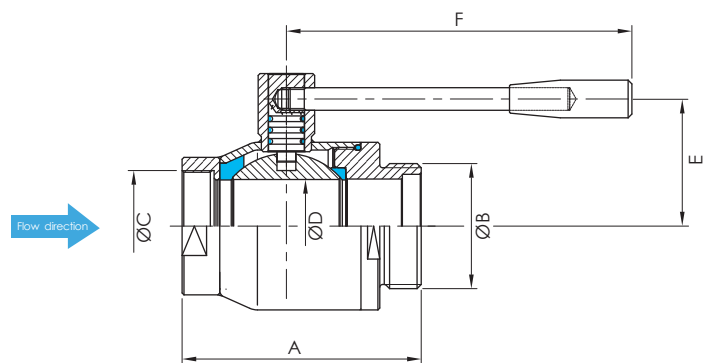

art. 84A

## Valvola a sfera RS maschio girella - filetto macon

RS ball valve macon nut and liner - male end

RS Kugelventil Macon KM/G

Vanne à boule RS femelle - mâle macon

Válvula de bola RS tuerca - macho macon

DN	A	B	C	D	E	F
40	127	55x3	40	64	185	
50	137	67x3	50	68	185	
60	150	79x3.5	60	73	205	
70	161	90x3.5	70	95	243	
80	180	102x4	80	104	243	
100	204	125x4	100	122	273	
125	225	146x4	117	135	273	

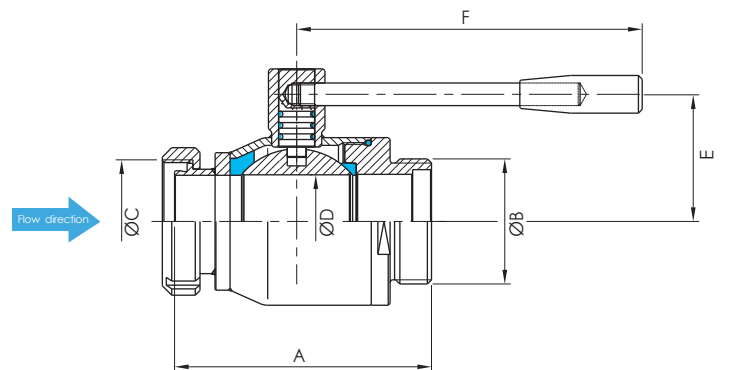

art. 84B

## Valvola a sfera RS saldare - filetto macon

RS ball valve weld - macon male end

RS Kugelventil S - Macon G

Vanne à boule RS souder - mâle macon

Válvula de bola RS soldar - macho macon

DN	A	B	C	D	E	F
40	127	55x3	43.5	40	64	185
50	137	67x3	53.5	50	68	185
60	150	79x3.5	63.5	60	73	205
70	161	90x3.5	73.5	70	95	243
80	180	102x4	83.5	80	104	243
100	204	125x4	103.5	100	122	273
125	225	146x4	123.5	117	135	273

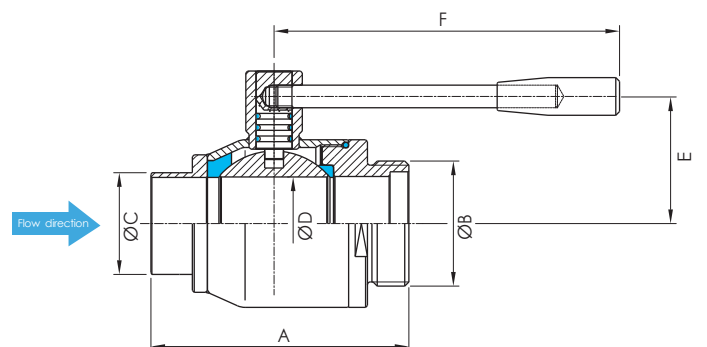

art. 84C

## Kit guarnizioni di ricambio valvole RS

RS ball valve seal kit

Ersatz-Dichtungen für RS Kugelventilen

Kit joints de rechange pour vannes RS

Kit juntas de repuesto válvulas RS

POS.	DENOMINAZIONE	PART NAME	MATERIALE / MATERIAL
5	SEDE SFERA	BALL SEAT	PTFE
6	SEDE SFERA	BALL SEAT	PTFE + VETRO / PTFE + GLASS
7	OR CUFFIA	CAP OR	EPDM / NBR / SILICONE / VITON
8	OR PERNO	PIN OR	EPDM / NBR / SILICONE / VITON

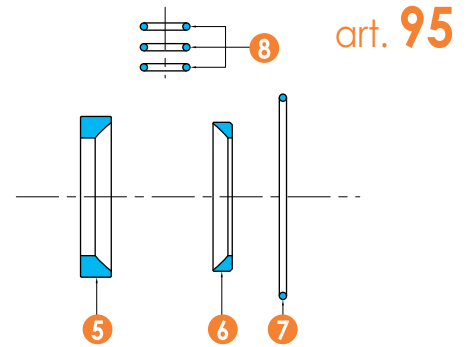

## Maniglia inox valvola Mod. RS

S.S. handle RS model

Edelstahl Griff für RS Ventil

Poignée inox pour vanne mod. RS

Mando inox por válvula mod. RS

AISI 304

DN	A	B	C	D	E
3/8"÷1"	120	55	18	10	M8
1/4"	150	55	18	10	M8
1/2"÷2"	183	65	20	12	M12
2/4"	208	65	20	12	M12
2 1/2"÷3"	244	90	25	15	M14
3 1/2"÷4"÷5"	274	90	25	15	M14

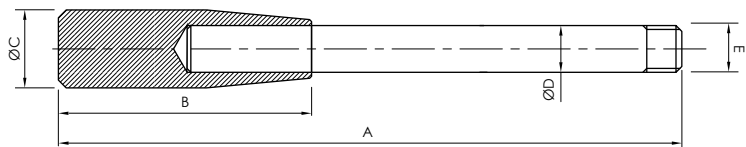

art. 96

## Maniglia inox per valvola RS MOD. RSK

S.S. handle - RSK model

Edelstahl Griff für RSK ventil

Poignée inox pour vanne mod. RSK

Maneta inox por válvula mod. RSK

TIPO	A	B	C	D	E	F	G
15 ÷ 32	28	28	122	55	10	18	9
40 ÷ 50	37	34	180	65	12	20	14
65 ÷ 150	54	41	266	90	15	25	17

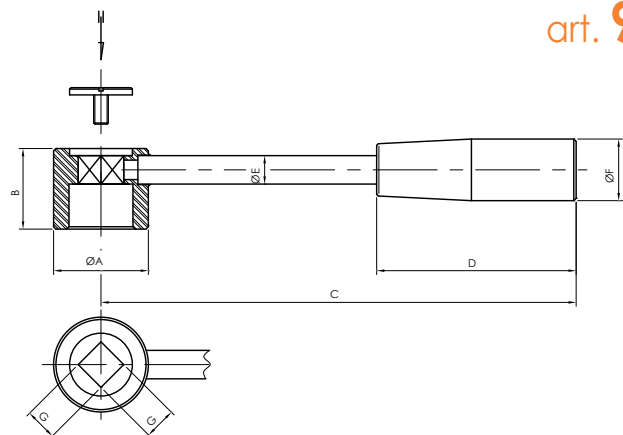

art. 96A

## Maniglia inox RS con microswitch Open/closed

S.S. RS handle with open/closed proximity switch

Edelstahl Griff für RS ventil mit proximity switch

Poignée inox pour vanne RS avec proximity switch

Maneta inox por válvula RS con proximity switch

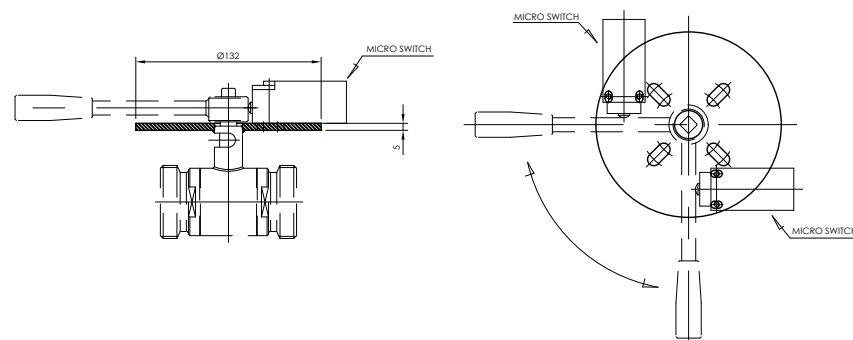

rt. 96B

## Valvola a sfera a guarnizioni inglobanti

Two-way ball valve with encapsulated gaskets

2-Wege Kugelhahn Totraumfrei

Vanne à boule avec joints enveloppants

Válvula de bola con sellos envolventes

art. 98

DN	A	ØB	H	L
20	90	25.4	65	105
25	110	50.4	70	105
38	140	50.4	80	130
51	164	63.9	85	150
63	180	77.5	110	180

**Valvola a sfera adatta ad essere impiegata per prodotti densi - dove è necessario lo smontaggio e la pulizia ordinaria adatte per l'industria alimentare, chimica, cosmetica e farmaceutica.**

Ball valve suitable for use for dense products, where it is necessary an easy disassembly and cleaning routine. It is suitable for the food industry, chemical, cosmetic and pharmaceutical.

Kugelhahn für den Einsatz für dichte Produkte, wo Man muss Demontage und Reinigung Routine einfach machen. Es ist für die Lebensmittelindustrie geeignet, chemischen, kosmetischen und pharmazeutischen.

Vanne à boule apte à l'utilise avec de produits denses, où est-il nécessaire le démontage et le nettoyage de routine. Ce modèle est conseillé pour l'industrie alimentaire, chimique, cosmétique et pharmaceutique.

Válvula de bola conveniente para el uso de productos densos, donde es necesario el desmontaje y limpieza de rutina. Es apropiado para la industria alimentaria, química, cosmética y farmacéutica

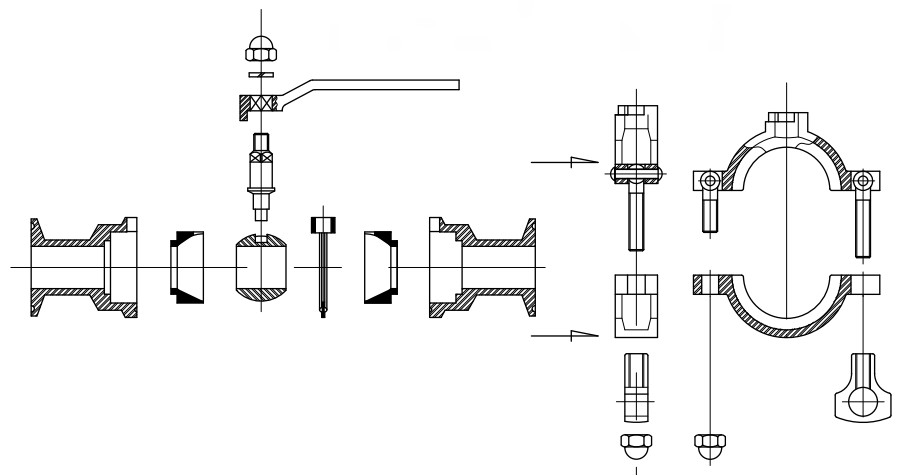
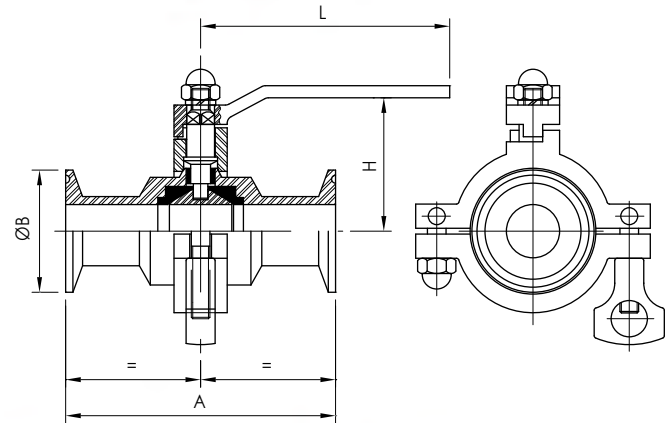

### CARATTERISTICHE TECNICHE

- Costruita da pezzi forgiati AISI 316L
- Maniglia ad apertura a 90°, attuata elettricam. o ad aria
- Guarnizioni in PTFE inglobanti
- Passaggio totale
- Connessioni standard Clamp BS 4825
- Fluidi di contatto di gruppo 2
- Finitura standard ra 0,8 ext. / 0,4 int.
- Pressione di esercizio PN10
- Temperatura da -20° +150°
- Collaudo 100%

### TECHNICAL DATA

- Built by forged pieces AISI 316L
- 90° opening handle or by electrical or pneumatic actuators
- Encapsulated gaskets in PTFE
- Full bore
- Standard connections Clamp BS 4825
- Fluid of contact of group 2
- Standard finish Ra 0,8 ext./0,4 int.
- Pressure of working PN10
- Temperature from - 20° to + 150°
- 100% Tested

Le informazioni contenute in questo documento sono puramente indicative e non impegnative, l'azienda si riserva il diritto di modificarle senza obbligo di preavviso.  
The informations provided in this document are intended for informational purposes only and are subject to change without notice.

